

# INSTRUCTION MANUAL

## ST-12D Table Saw (240V) 305mm



**W454**

## General Safety Information

**WARNING: DISCONNECT POWER BEFORE SERVICING.**

**WARNING: DO NOT ALLOW FAMILIARITY (GAINED FROM FREQUENT USE OF TABLE SAW) TO BECOME COMMONPLACE. ALWAYS REMEMBER THAT A CARELESS FRACTION OF A SECOND IS SUFFICIENT TO INFLICT SEVERE INJURY.**

1. For your own safety read instruction manual before operating saw.

**WARNING: DO NOT OPERATE SAW IN GASEOUS OR EXPLOSIVE ATMOSPHERES. MOTORS AND SWITCHES CREATE SPARKS AND MAY CAUSE AN EXPLOSION.**

2. Avoid accidental starting. Make sure switch is in "OFF" position before turning on safety disconnect or activating breaker.
3. Wear eye protection.
4. Do not remove jammed cutoff pieces until blade has stopped.
5. Maintain proper adjustment of rip fence and blade guard.
6. Never adjust saw while running. Disconnect power to avoid accidental start-up.
7. Hold workpiece firmly against table.
8. Saw must be grounded. Install and wire saw in accordance with local codes and ordinances.

**WARNING: NEVER ALTER THE AC POWER CORD OR ANY ELECTRICAL COMPONENTS ON THIS EQUIPMENT.**

9. Use only manufacturer recommended accessories and attachments.
10. Have all electrical work performed by a qualified electrician.
11. Follow all local electrical and safety codes, the National Electrical Code (NEC) and the Occupational Safety and Health Act (OSHA).
12. Permanently (hard) wire saw directly to fused safety disconnect.
13. Connect the green, or green and yellow, conductor to the motor ground.

**WARNING: NEVER CONNECT THE GREEN OR GREEN AND YELLOW CONDUCTOR TO A LIVE TERMINAL!**

14. Properly ground the stationary saw by using a grounded metal-clad raceway system or a properly grounded 3-prong receptacle.
15. Use this equipment on 230VAC circuits only.
16. Be sure saw is properly grounded.
17. Keep power cords from coming in contact with sharp objects, oil, grease and hot surfaces.
18. Have damaged or worn power cords replaced immediately.
19. Keep guards in place and in working order.
20. Remove all adjusting keys and tools from the saw before turning it on.
21. Keep the work area clean.
22. Do not expose the saw to rain or damp and wet locations.
23. Keep the work area well lighted.
24. Keep hands away from blade and other moving parts.

25. Keep children and visitors a safe distance from the work area.
26. Use padlocks, master switches, or remove starter keys to prevent unauthorized personnel from using the equipment.
27. Do not force tools. They operate better and safer when used at their intended feed rate.
28. Use the right tool for the job.
29. Do not wear personal metal items: watches, rings, etc., when working with cutting machinery.
30. Do not wear loose clothing.
31. Wear safety shoes with non-slip soles.
32. Wear protective hair covering to contain long hair.
33. If cutting operations are dusty, wear a face shield along with safety glasses.
34. Always secure the work with clamps or vises.
35. Never overreach, and keep your balance at all times.
36. Keep the saw blade sharp for best and safest operation.
37. Never operate the saw when you are tired.
38. Always check that the equipment switch is in the "OFF" position before turning "ON" breaker or safety disconnect.
39. Never stand on the tool.
40. Check the tool for damaged parts before each use.
41. Replace or repair damaged or worn parts immediately with identical replacement parts.
42. Repair or replace damaged guards immediately.
43. Feed the work into the blade only as recommended in Operation.
44. Never leave the saw unattended while it is running.
45. If motor is used with no thermal protection the motor should be wired directly to a sufficient breaker box by a qualified electrician.

**WARNING: FOR YOUR OWN SAFETY, DO NOT OPERATE YOUR SAW UNTIL IT IS COMPLETELY ASSEMBLED AND INSTALLED ACCORDING TO THE INSTRUCTIONS... AND UNTIL YOU HAVE READ AND UNDERSTAND THE FOLLOWING:**

### STABILITY OF SAW

If there is any tendency for the saw to tip over or move during certain cutting operations such as cutting extremely large heavy panels or long heavy boards, the saw should be bolted down. If you attach any kind of table extensions over 24" wide to either end of the saw, make sure you either bolt the saw to the floor as appropriate, or support the outer end of the extension from the bench or floor, as appropriate.

### LOCATION

The saw should be positioned so neither the operator nor a casual observer is forced to stand in line with the saw blade.

### KICKBACKS

A "KICKBACK" occurs during a rip-type operation when a part or all of the workpiece is thrown back violently toward the operator.

Keep your face and body to one side of the sawblade, out of line with a possible "Kickback."

## General Safety Information (Continued)

Kickbacks — and possible injury from them — can usually be avoided by:

- A. Maintaining the rip fence parallel to the sawblade.
- B. Keeping the sawblade sharp. Replace or sharpen antikickback pawls when points become dull.
- C. Keeping sawblade guard, spreader, and antikickback pawls in place and operating properly. The spreader must be in alignment with the sawblade and the pawls must stop a kickback once it has started. Check their action before ripping.
- D. NOT ripping work that is twisted or warped or does not have a straight edge to guide along the rip fence.
- E. NOT releasing work until you have pushed it all the way past the sawblade.
- F. Using a push stick for ripping widths less than 6 inches.
- G. NOT confining the cutoff piece when ripping or crosscutting.

### PROTECTION: EYES, HANDS, FACE, EARS, BODY

- A. If any part of your saw is missing, malfunctioning, or has been damaged or broken...such as the motor switch, electronic controls, or other operating control, a safety device or the power cord...cease operating immediately until the particular part is properly repaired or replaced.
- B. Wear safety goggles that comply with ANSI Z87.1, and a face shield or dust mask if operation is dusty. Wear ear plugs or muffs during extended periods of operation.
- C. Small loose pieces of wood or other objects that contact the rear of the revolving blade can be thrown back at the operator at excessive speed. This can usually be avoided by keeping the guard and spreader in place for all thru-sawing operations (sawing entirely thru the work) AND by removing all loose pieces from the table with a long stick of wood IMMEDIATELY after they are cut off.
- D. Use extra caution when the guard assembly is removed for resawing, dadoing, or rabbeting — replace the guard as soon as that operation is completed.
- E. For rip or rip-type cuts, the following end of a workpiece to which a push stick or push board is applied must be square (perpendicular to the fence) in order that feed pressure applied to the workpiece by the push stick or block does not cause the workpiece to come away from the fence, and possibly cause a kickback.
- F. During rip and rip-type cuts, the workpiece must be held down on the table and against the fence with a push stick, push block, and featherboards, as required. A featherboard is made of solid lumber (at least 3/4" thick) per sketch.

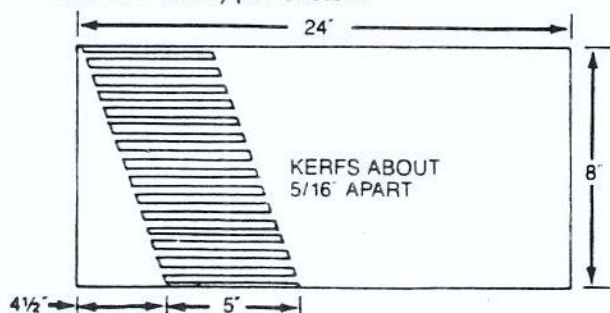

- G. NEVER turn the saw "ON" before clearing the table of all tools, wood scraps, etc., except the workpiece and related feed or support devices for the operation planned.
- H. NEVER place your face or body in line with the cutting tool.
- I. NEVER place your fingers or hands in the path of the sawblade or other cutting tool.
- J. NEVER reach in back of the cutting tool with either hand to hold down or support the workpiece, remove wood scraps, or for any other reason. Avoid awkward operations and hand positions where a sudden slip could cause fingers or hand to move into a sawblade or other cutting tool.
- K. DO NOT perform layout, assembly, or setup work on the table while the cutting tool is rotating.
- L. DO NOT perform any operation "FREEHAND" — always use either the rip fence or the miter gauge to position and guide the work.
- M. NEVER use the rip fence when crosscutting or the miter gauge when ripping. DO NOT use the rip fence as a length stop. Never hold onto or touch the "free end" of the workpiece or a "free piece" that is cut off, while power is "ON" and/or the sawblade is rotating.
- N. Shut "OFF" the saw and disconnect the power source when removing the table insert, changing the cutting tool, removing or replacing the blade guard, or making adjustments.
- O. Provide adequate support to the rear and sides of the saw table for wider or long workpieces.
- P. Plastic and composition (like hardboard) materials may be cut on your saw. However, since these are usually quite hard and slippery, the antikickback pawls may not stop a kickback. Therefore, be especially attentive to following proper setup and cutting procedures for ripping. Do not stand, or permit anyone else to stand in line with a potential kickback.
- Q. If you stall or jam the sawblade in the workpiece turn saw "OFF" and remove the workpiece from the sawblade. Check to see if the sawblade is parallel to the miter gauge grooves and if the spreader is in proper alignment with the sawblade. If ripping at the time, check to see if the rip fence is parallel with the sawblade. Readjust as indicated.
- R. DO NOT remove small pieces of cutoff material that may become trapped inside the blade guard while the saw is running. This could endanger your hands or cause a kickback. Turn saw "OFF" and wait until blade stops.
- S. Use extra care when ripping wood that has a twisted grain or is twisted or bowed — it may rock on the table and/or pinch the sawblade.

### KNOW YOUR CUTTING TOOLS

- A. Dull, gummy, or improperly sharpened or set cutting tools can cause material to stick, jam, stall the saw, or kickback at the operator.  
Minimize potential injury by proper cutting tool and machine maintenance.  
**WARNING: NEVER ATTEMPT TO FREE A STALLED SAWBLADE WITHOUT FIRST TURNING THE SAW OFF.**
- B. Never use grinding wheels, abrasive cutoff wheels, friction wheels (metal slitting blades), wire wheels or buffing wheels.

## General Safety Information (Continued)

### USE ONLY ACCESSORIES DESIGNED FOR THIS SAW

- A. Crosscutting operations are worked more conveniently and with greater safety if an auxiliary wood facing is attached to the miter gauge using the holes provided. However, the facing must not interfere with the proper functioning of the sawblade guard.
- B. Make sure the top of the arbor or cutting tool rotates toward you when standing in normal operating position. Also make sure the cutting tool, arbor collars and arbor nut are installed properly. Keep the cutting tool as low as possible for the operation being performed. Keep all guards in place whenever possible.
- C. Do not use any blade or other cutting tool marked for an operating speed less than 4000 RPM. Never use a cutting tool larger in diameter than the diameter for which the saw was designed. For greatest safety and efficiency when ripping, use the maximum diameter blade for which the saw is designed, since under these conditions the spreader is nearest the blade.
- D. Adjust table inserts flush with the table top. NEVER operate the saw unless the proper insert is installed.
- E. NEVER feed material into the cutting tool from the rear of the saw. An accident and serious injury could result.

### THINK SAFETY

Safety is a combination of operator common sense and alertness at all times when the saw is being used.

NEVER use another person as a substitute for a table extension, or as additional support for a workpiece that is longer or wider than the basic saw table, or to assist in feeding or supporting or pulling the workpiece.

DO NOT pull the workpiece through the sawblade — position your body at the nose (infeed) side of the guard: start and complete the cut from that same side. This will require added table support for long or wide workpieces that extend beyond the length or width of the saw table.

**WARNING: FOLLOW SAFETY INSTRUCTIONS THAT APPEAR ON THE FRONT OF YOUR SAW.**

**WARNING: DO NOT ALLOW FAMILIARITY (GAINED FROM FREQUENT USE OF YOUR SAW) TO BECOME COMMONPLACE. ALWAYS REMEMBER THAT A CARELESS FRACTION OF A SECOND IS SUFFICIENT TO INFLECT SEVERE INJURY.**

**WARNING: THE SAW PULLEY AND THE MOTOR PULLEY FURNISHED, WILL RUN THE BLADE AT APPROXIMATELY 4000 RPM WHEN USED WITH A 3500 RPM MOTOR. NEVER SUBSTITUTE THESE PULLEYS TO INCREASE THIS SPEED BECAUSE IT COULD BE DANGEROUS.**

NOTE: Do not overtighten arbor nut. Use the arbor wrench to just "snug" it.

The operation of any power tool can result in foreign objects being thrown into the eyes, which can result in severe eye damage. Always wear safety goggles complying with ANSI Z87.1 before commencing power tool operation.

**WARNING: DO NOT UNDER ANY CIRCUMSTANCES ATTEMPT TO SERVICE, REPAIR, DISMANTLE, OR DISASSEMBLE ANY OF THE MECHANICAL OR ELECTRICAL COMPONENTS WITHOUT PHYSICALLY DISCONNECTING ALL POWER SOURCES.**

## Assembly

Use Figures 3, 4 and 5 as general reference. Be certain all parts are clean and free of shipping preservative. Also, completely remove all parts of crate and packing. Saw cabinet should be directly on the floor. To clean and unpack see Unpacking, page 1.

### A. ASSEMBLE SAW

1. Positioning the saw on a level surface (shimming may be required) will improve stability and accuracy and prevent warpage and failure of cast components and welds. Level the saw using shims or machine mounts. The stationary saw's base is fitted with four mounting holes. The holes are located within a yellow recess. Use these holes to secure stationary saw to the floor. This saw should be permanently fastened to the floor. This will decrease vibration and increase stability.
2. Installation of motor: (Refer to Figure 3).
  - a. Assemble motor pulley (Ref. No. 80) to motor shaft, engaging motor pulley setscrew, 8 mm — 1.25 x 8 (Ref. No. 81) with key in motor shaft. Assemble the motor pulley so the motor pulley hub is on the outboard side away from the motor. Be sure entire motor pulley is placed over motor shaft. Only finger tighten the setscrew; motor pulley still needs to be aligned.
  - b. When installing motor, remove motor mount plate (Ref. No. 71). First, remove hex head bolt and washer (Ref. No. 35 and 36). Next, remove cotter pin (Ref. No. 37) and release shouldered pivot shaft (Ref. No. 34).
  - c. Attach motor mount plate to motor using four (4) each hex bolts, lockwashers and nuts (Ref. Nos. 72, 69 and 70). Position the motor on the plate so shaft and pulley will fall below the drive pulley (Ref. No. 40) when mounted. Hand tighten bolts firmly. Alignment of motor and final tightening of bolts will occur after belts are installed.
  - d. Install motor and plate assembly to motor support casting (Ref. No. 62). To secure plate, first install pivot shaft (Ref. No. 34) and cotter pin (Ref. No. 37). Second, fasten the tension adjustment bolts and washers (Ref. Nos. 35 and 36). Finger tighten loosely.

NOTE: The motor and plate assembly is heavy and care should be exercised while installing. Installation of motor is recommended with two people and the use of wood blocks for supporting the motor while securing.



## Assembly (Continued)

- e. The 12" stationary saw uses a three V-belt drive system. Install the V-belts. First place V-belts into position on drive pulley (top) (Ref. No. 40). Raise the motor mount plate to release tension. Slip belts onto motor pulley. Do not tighten belts. However, straighten belts for alignment purposes.
- f. Align pulleys. Simultaneously adjust motor mount plate so that the drive pulley and motor pulley are directly in line and parallel (use straightedge if necessary). Good alignment is essential for efficient saw performance. Belt life and operating efficiency are all related to pulley alignment. Once pulleys are aligned, tighten securely motor mount bolts, washers, and nuts (Ref. Nos. 72, 69 and 70). If necessary, adjust pulley alignment again by moving motor pulley only. Tighten 8 mm — 1.25 x 8 motor pulley setscrew (Ref. No. 81) securely.
- g. Tighten V-Belts. V-belts are tensioned by raising or lowering the motor. Loosen tension adjustment bolts and washers (Ref. Nos. 35 and 36). Lower motor, allow weight of motor to tension V-belts. Correct tension is obtained when there is approximately 1/4" deflection of the belt at the center span of the pulleys, using light finger pressure. Do not over-tension. Tighten the tension adjustment bolts and washers (Ref. Nos. 35 and 36) securely.
3. (Refer to Figures 3 and 4.) Install blade guard bracket (Figure 3, Ref. No. 52) with two (2) each socket head bolts. Finger tighten. Install guard support rod (Figure 4, Ref. No. 37). Insert rod through hole in rear trunnion (Figure 3, Ref. No. 77) and secure with lockwasher and nut (Figure 3, Ref. Nos. 54 and 55). The threads of the guard support rod are machined on an eccentric. This allows for adjustment of the back of the blade guard. By rotating the support rod the rod will move off center, allowing for different positions. Alignment and final tightening of support rod (Figure 4, Ref. No. 37) and guard bracket (Figure 3, Ref. No. 52) will occur when blade guard is installed (Section C, page 7).
4. Installation of arbor extension (Refer to Figure 3)
- Wipe clean flange and taper on inside of flange on arbor (Ref. No. 7).
  - Wipe clean taper and threads of arbor extension (Ref. No. 6). It is recommended when installing that a dry lubricant be used on the taper end of the arbor extension.
  - Install arbor extension (Ref. No. 6) into arbor (Ref. No. 7). The arbor extension for standard 12" blades is 1" O.D. x 3" long. By hand, thread the arbor extension counterclockwise into the arbor. Secure arbor extension by inserting 8mm hex wrench (Ref. No. 84) into 8mm socket at outboard end of extension and tighten. Arbor itself is held in place with spanner wrench (Ref. No. 85). Place spanner wrench on the inside blade flange with the two prongs on the spanner wrench inserted into the two holes in the flange. Seat arbor extension firmly. However, it is not necessary to excessively tighten.
- NOTE: To remove an arbor extension, the reverse is applied.
5. Install the blade: (Refer to Figure 3)
- Position blade on arbor extension so that blade is flush against inside of arbor flange and teeth point towards front of saw. Blade must have correct hole I.D. of 1" to be accepted by arbor extension. Oversized I.D. will not work.  
**IMPORTANT: BLADE ROTATES TOWARDS FRONT OF SAW. WHEN INSTALLING THE BLADE, MAKE SURE THE TEETH ARE POINTING TOWARDS THE FRONT OF THE SAW.**
  - Place the outside blade flange (Ref. No. 5) against the blade. The hollow side (large O.D.) must be against blade. Secure flange with arbor nut (Ref. No. 4). Hand tighten arbor nut (Ref. No. 4) counterclockwise. Tighten arbor nut with box wrench (Ref. No. 85 spanner wrench with pins facing outward.) If necessary, while tightening arbor nut, hold arbor extension in position with 8 mm hex wrench inserted into end of extension.  
**NOTE: DO NOT overtighten arbor nut. Use the box wrench to just "snug" it.**  
Remove box wrench and hex wrench.
6. Install miter gauge: (Refer to Figure 4)
- The miter gauge comes pre-assembled. Unpack the miter gauge and clean thoroughly.
  - Be certain miter gauge "T" slots in table are also thoroughly cleaned.
  - The miter gauge is guided through the "T" slot with a roller guide at the front of guide bar. To insert miter gauge, first insert roller guide into "T" slot at front of table.
7. Assemble hand wheels (Ref. Nos. 30 and 36). Both hand wheels are identical.
- Attach crank handles (Ref. No. 28) securely to hand wheels (Ref. Nos. 30 and 36).
  - The hand wheels are attached to the tilt adjustment shaft (Figure 3, Ref. No. 26) and the height adjustment shaft (Figure 3, Ref. No. 75).
  - Install washer (Figure 3, Ref. No. 1) on shaft.
  - Place key (Figure 3, Ref. No. 28) in keyway.
  - Assemble hand wheel to shaft engaging setscrew (Figure 4, Ref. No. 33) with key in shaft. Position hand wheel onto shaft as far as possible without interfering with movement. Tighten setscrew.
  - Install locking knobs (Figure 4, Ref. No. 26). Insert threaded portion of knobs into end of shafts. Gently hand tighten knob until it stops. This is the locked position. To unlock, back out the knob three complete turns. For the time being leave hand wheels unlocked.  
**NOTE: Do not overtighten locking knobs.**
8. Adjusting miter gauge slots parallel to saw blade.  
**IMPORTANT: THIS ADJUSTMENT IS CRITICAL TO THE ACCURACY OF THIS SAW.**
- All 12" stationary saws are shipped from the factory with the table adjusted so the miter gauge slots are parallel to the saw blade. However, in order to obtain the best results from the saw, it is suggested this adjustment be checked before operating.

### Assembly (Continued)

- b. A simple method of checking the alignment is as follows:
- Bolt or clamp a dowel rod or similar object to the miter gauge (a combination square can be substituted).
  - Pick out a tooth on the front of the blade and set the dowel to it so it is just touching.
  - Move this same tooth of the blade to the back of the blade.
  - Gauge this tooth with the dowel rod. If the tooth is in the same position, relative to the miter gauge, the table is parallel with the blade.
  - In short: The miter gauge slots must be parallel with the blade. This means that when measuring the distance between the blade and the slot at the front and rear of the blade, the distances will be equal (see below).

NOTE: Be positive to measure the distance or make the test on the same tooth of the saw blade in both front and rear positions.

### 9. Assemble table extensions (Refer to Figure 4)

- Be certain both edges of table (Ref. No. 8) and table extension (Ref. No. 1) are clean and free from any preservative, debris or burrs.
- Attach each table extension with 10 mm - 1.5 x 35 hex head bolts and lockwashers (Ref. Nos. 2 and 3) (three each). Fasten the hex head bolts and lockwashers to matching tapped holes in table. Hand tighten.
- Using a straightedge set top of extension flush with the table top. Extension should also be centered front to rear. First, slightly tighten the center bolt. If either end is not flush, tap extension up or down with rubber mallet. Bring extension in line with table. Securely tighten one bolt at a time, keeping extension flush with table top.

ADJUSTMENT BOLTS (FIGURE 4) 10 mm - 1.5 x 30  
Hex head capscrews and lockwashers (Ref. Nos. 16 & 15)

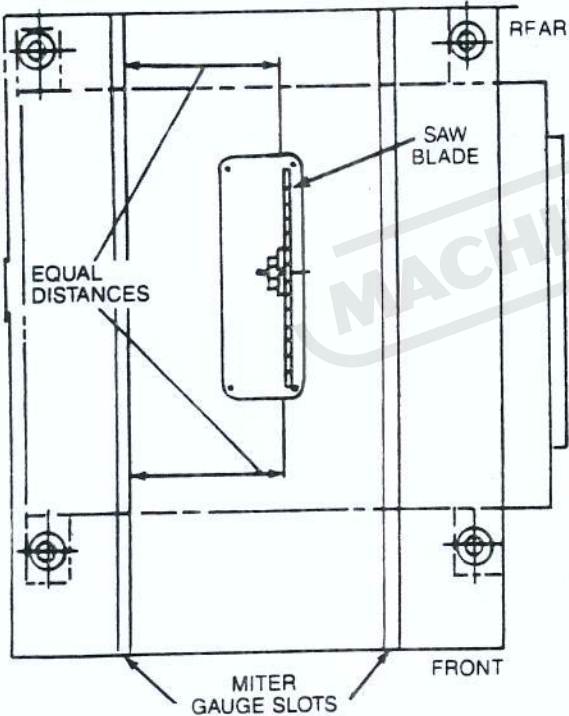

- c. If an adjustment is necessary, proceed as follows: (Refer to Figure 4)
- Loosen the 10 mm - 1.5 x 30 hex head capscrews and lockwashers (Ref. Nos. 16 and 15) (four each) which fasten the table (Ref. No. 8) to the cabinet (Ref. No. 9).
  - Shift the table until a position is found where the saw blade is parallel to the miter gauge slots.
  - NOTE: saw blade should also be centered within its table insert opening.
  - Tighten the 10 mm - 1.5 x 30 hex head capscrews and lockwashers (Ref. Nos. 16 and 15) (four each) very securely. This procedure will set the table in parallel position and prevent the table from shifting.

## **Assembly (Continued)**

### **C. INSTALLATION OF BLADE GUARD**

1. Lower blade as far as possible and set tilt angle at 90°.
2. Assemble blade guard brackets (Figure 4, Ref. Nos. 40 & 42) to support rod (Figure 4, Ref. No. 37).
  - a. Brackets should be securely assembled with hex head bolt and washer (Figure 4, Ref. Nos. 38 and 39).
  - b. Attach bracket (Figure 4, Ref. No. 42) to support rod with one each hex head bolt and lockwasher (Figure 4, Ref. Nos. 38 and 41). Hand tighten only.
3. Check that front attachment bracket (Figure 3, Ref. No. 52) is in position. Insert and start front guard attachment bolt and washer (Figure 3, Ref. Nos. 50 and 51). Do not tighten.
4. Install blade guard assembly
  - a. Position blade guard so it points toward front of saw.
  - b. Attach front of "spreader" (Figure 2, Ref. No. 6) to front attachment bracket (Figure 3, Ref. No. 52) with hex bolt, and washer (Figure 3, Ref. Nos. 50 and 51). Hand tighten, allow for adjustment.
  - c. Attach rear of spreader to rear blade guide bracket. Fasten with rear guard attachment bolt and washer (Figure 4, Ref. Nos. 44 and 43). Hand tighten; allow for adjustment.
  - d. Blade guard assembly is now attached; however, it is not useable until completely adjusted. The clear blade guard (Figure 2, Ref. No. 2) should point forward.

**IMPORTANT: BE CERTAIN THE ACRYLIC BLADE GUARD AND THE ANTIKICKBACK PAWLS ARE SPRING LOADED, FORCING THEM DOWN TO THE TABLE SURFACE. BOTH BLADE GUARD AND ANTIKICKBACK PAWLS SHOULD AUTOMATICALLY RETURN TO TABLE SURFACE AFTER BEING LIFTED.**

**NOTE:** The teeth of the antikickback pawls (Figure 2, Ref. No. 9) should be angled toward the rear of the saw. This safety device is to help prevent workpiece from being thrown back at operator.

### **5. Adjusting blade guard**

- a. **IMPORTANT: THE SPREADER MUST ALWAYS BE PARALLEL TO THE SAW BLADE AND IN THE MIDDLE OF THE CUT (KERF) MADE BY THE SAW BLADE. IN SHORT, THE SPREADER MUST ALWAYS BE IN THE EXACT SAME PLANE AS THE SAW BLADE. IF THE SPREADER IS NOT IN THE SAME PLANE AS SAW BLADE, IT WILL INTERFERE WITH THE EXISTING WORKPIECE IN ADDITION TO CAUSING POOR AND UNSAFE GUARD OPERATION.**
- b. Raise blade to full height.
- c. Adjust tilt angle of blade to 90°. Use a hand square to be certain blade is perpendicular (90°) to table. Lock tilt angle at 90° with tilt hand wheel (Fig. 4, Ref. No. 36).

**NOTE:** If tilt angle will not go to 90° an adjustment to the 90° stop is necessary. If so, see Operation — 90° Stop Adjustment (Section C, page 10).

- d. When adjusting spreader use a straightedge lengthwise along blade to be certain spreader is trailing in the middle of the kerf (cut). In addition use a 90° hand square to make sure spreader is perpendicular to the table, as is the blade.
- e. Align front of spreader with blade.
  - i. If necessary adjust front attachment bracket (Figure 3, Ref. No. 52).
  - ii. **NOTE:** In order to adjust this bracket it may be necessary to lower saw blade.
  - iii. To adjust, loosen socket head bolts (Figure 3, Ref. No. 53).
  - iv. When complete secure socket head bolts tightly.
- f. To adjust the height of the front of the spreader loosen front attachment bolt and washer (Figure 3, Ref. Nos. 50 and 51) and position spreader up or down. Lock spreader into position by tightening hex head attachment bolt and washer. Height of spreader should be adjusted to allow blade guard to contact table.
- g. Align rear of spreader.
  - i. Rear of spreader can be adjusted by turning the support rod on its eccentric. Turning the rod will in effect move the rear bracket left or right. After spreader is completely lined up in the middle of the kerf, tighten rod hex nut and lockwasher (Figure 3, Ref. Nos. 55 and 54). Tighten securely.

## Assembly (Continued)

NOTE: It may be necessary to lower or remove blade to tighten hex nut and lockwasher (Figure 3, Ref. Nos. 55 and 54).

- ii. Adjust angle (90°) of spreader to table. Loosen hex bolt and lockwasher (Fig. 4, Ref. Nos. 38 & 41). Rotate rod bracket (Fig. 4, Ref. No. 40) until spreader is perpendicular (90°) to table. Tighten hex bolt and lockwasher.
- iii. Adjust the height of the rear of the spreader so top edge is parallel with table. Loosen rear attachment bolt and washer.

NOTE: It may be necessary to also loosen front attachment bolt and washer. Adjust height so top edge is parallel. Lock into position. Tighten both front and rear attachment bolts and washers (Figure 4, Ref. Nos. 44 and 43, Figure 3, Ref. Nos. 50 and 51).

- h. The blade guard is now assembled and adjusted. The spreader should be parallel with saw blade and in the middle of the kerf. If this is not true, repeat all adjustment steps. Before operating saw recheck all blade guard fasteners to be certain all are securely tightened.

**IMPORTANT: BEFORE OPERATING SAW, BE CERTAIN BLADE GUARD AND ANTIKICKBACK PAWLS AUTOMATICALLY RETURN TO TABLE SURFACE.**

### D. INSTALLATION OF TABLE INSERTS

(Standard Insert Figure 4, Ref. No. 6 and Dado Insert Figure 4, Ref. No. 52.)

1. Be certain table inserts are clean.
2. Lower blade below table.
3. Place standard insert into position with cut-out on blade side.
4. Surface of insert should be flush with table surface.
5. Using a straightedge, check insert to see if it is flush with table.
6. To adjust insert, remove insert from table and turn it upside down on work bench.
  - a. Each corner of table insert is fitted with a 6 mm adjusting setscrew (Ref. No. 7).
  - b. Adjust each corner of insert up or down to bring insert flush with table top.
  - c. Be certain all four setscrews are firmly seated on table casting.
7. Repeat procedure for dado insert (Ref. No. 52).
8. Replace standard table insert (Ref. No. 6).
9. **CAUTION: Only use dado insert (Ref. No. 52) with dado blade set. Only use standard insert (Ref. No. 6) with standard 12" blade. Never attempt to interchange; only use table insert with the blade it was intended to be used with.**

### E. WIRE MOTOR TO MAGNETIC STARTER

**WARNING: BE CERTAIN NO POWER SOURCE IS CONNECTED TO TABLE SAW.**

#### 1. Single-phase wiring

The motor to starter line cord is four conductor. The

green conductor is ground while the other three are power conductors. Single-phase power uses only three of these four conductors. The three conductors (leads) used are: green (green/yellow) for ground, and any two of the three remaining leads. The saw is already wired at the magnetic starter. The ground (green) is connected to the ground screw on the box. The black and the brown (red) leads are connected to terminals U/2 and W/6. The white (blue) lead is not used. Check the magnetic starter to be sure unused lead is white (blue). Once unused lead is determined, take the motor end of the line cord and tape the unused (white) lead against the line cord jacket.

#### 2. Wiring motor for clockwise rotation, single-phase operation

- a. Remove junction box cover.
- b. Feed line cord through strain relief area.
- c. Fasten the line cord ground lead (green) to the motor grounding screw. The motor grounding screw is easily found — it is green.
- d. The motor junction box should have six leads — T1, T2, T3, T4, T5 and T8. Locate all leads.
- e. Locate motor leads T2, T3 and T8. Connect these leads all together and securely.

NOTE: Be certain all connections are made with wire connectors or proper splices. Insulate all connections thoroughly with proper electrical tape.

- f. Locate motor lead T1. Connect lead T1 to the line cord lead that is fastened to magnetic starter terminal U/2. Adequately insulate connection.
- g. Locate motor leads T4 and T5. Connect leads T4 and T5 to the line cord lead that is fastened to magnetic starter terminal W/6. Adequately insulate connection.

NOTE: Leads on terminals U/2 and W/6 can be reversed with no effect on operation.

- h. Be certain ground wire is securely fastened and all connections are thoroughly insulated. Secure line cord from pulling out of junction box. Replace junction box cover.
- i. NOTE: Motor must run in a clockwise rotation. (Viewing the top of blade, the teeth must rotate from rear to front of saw.) If saw does not rotate in proper direction, wiring and all connections must be checked and corrected.

**WARNING: ONCE ROTATION IS CHECKED, DISCONNECT POWER BEFORE WORKING WITH MOTOR OR TOOL.**

### F. WIRE MAGNETIC STARTER TO SOURCE.

**WARNING: BE CERTAIN SWITCH IS IN "OFF" POSITION. DISCONNECT THE SOURCE OF ALL POWER. KEEP CIRCUIT BREAKER OPEN OR IN "OFF" POSITION.**

The saw should be connected to the power source with permanent wiring (hard wired). Power leads are to be supplied and connected by a qualified electrician.

**IMPORTANT: MOTOR AND MAGNETIC STARTER MUST BE PROPERLY GROUNDED. WIRING SHOULD BE PERFORMED BY A QUALIFIED ELECTRICIAN ACCORDING TO ALL LOCAL CODES AND ORDINANCES.**

### Assembly (Continued)

1. Be certain power leads are sufficient in size to adequately carry the saw's voltage and amp load.
2. Ground the magnetic starter. Connect the ground lead to the magnetic starter's ground screw or the attachment bolts. The ground lead will be green or green with yellow stripe. Fasten securely.
3. Connect power leads to magnetic starter terminals R/1 and T/5. Either lead can be placed on either terminal. Fasten securely.

**WARNING: DO NOT CONNECT POWER LEADS TO ANY OTHER TERMINAL OR FASTENER.**

4. When wiring the saw to the source, install a fused safety disconnect switch between the saw and the circuit breaker. Be certain the safety disconnect switch is capable of being locked in the "OFF" position. The safety disconnect switch is a safety precaution which allows the operator to *lock* the saw "OFF" so it is unable to receive power. This feature is intended to prevent accidental start-up when maintaining or servicing saw. In addition, it is intended to prevent unauthorized and possible hazardous use by others.

6. Wire the saw to a breaker box or fuse box with adequate capacity to accommodate the stationary saw's voltage and amp load.

7. **IMPORTANT: BE CERTAIN SAW IS WIRED TO A CIRCUIT PROTECTED BY A 30 AMP BREAKER OR FUSE.**

#### G. MAGNETIC STARTER

1. Terminals S3 and V4 are not used.
2. Magnetic starter is protected with a thermal overload. (Lower right-hand corner).
  - a. Be certain overload is positioned at manual (head) reset.
  - b. Position heater (overload) adjustment at middle amps.
3. Replace cover and secure all line cords.

Wiring Diagram For Single Phase

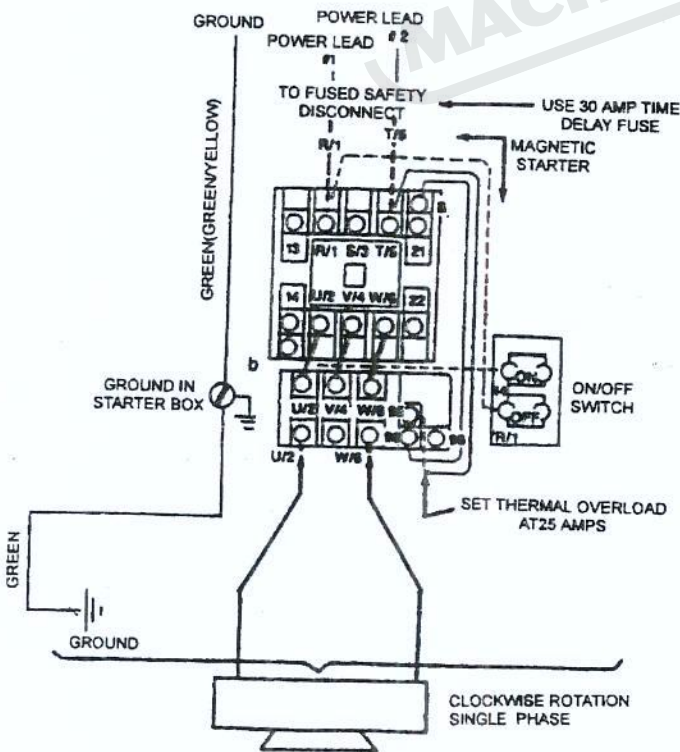

Wiring Diagram For Three Phase

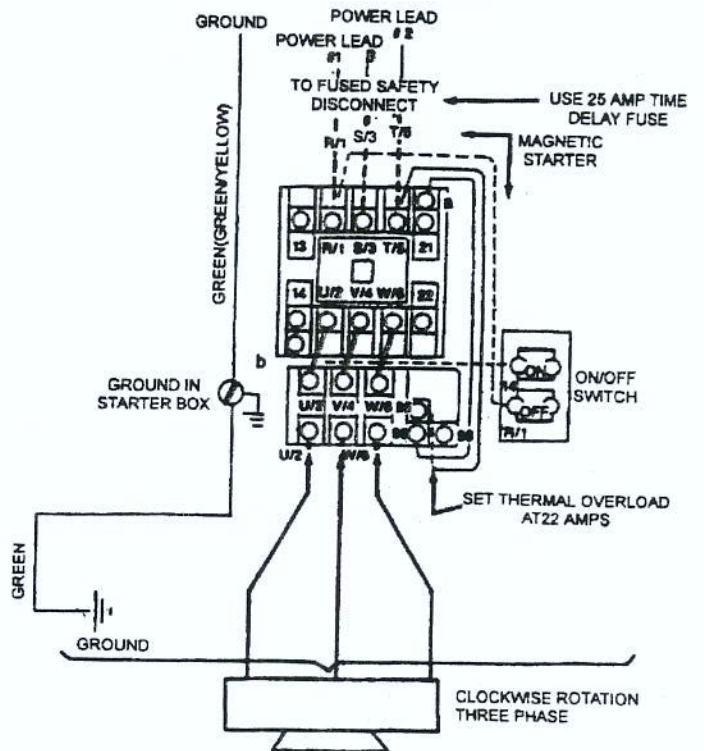

## Operation

**WARNING: DISCONNECT POWER BEFORE ATTEMPTING ANY OF THE FOLLOWING PROCEDURES. BE CERTAIN SWITCH IS IN "OFF" POSITION AND SAFETY DISCONNECT (OR BREAKER) IS IN "OFF" OR OPEN POSITION. SAW BLADE MUST NOT BE MOVING. SAW BLADE WILL ROTATE FREELY AFTER MOTOR IS TURNED OFF. ALLOW BLADE TO COME TO A COMPLETE STOP BEFORE ATTEMPTING ANY OF THE FOLLOWING PROCEDURES.**

A. INSTRUCTIONS for the following procedures have already been discussed in the Assembly section:

1. Installation and removal of arbor extension ..... Page 5, Section A (4)
2. Installation and removal of saw blade ..... Page 5, Section A (5)
3. Adjustment of table parallel with saw blade ..... Page 5, Section A (8)
4. Adjustment of blade guard ..... Page 7, Section C (5)
5. Adjustment of table insert ..... Page 8, Section D

B. BLADE HEIGHT ADJUSTMENT (Figure 4)

1. Blade height is controlled by the hand wheel (Ref. No. 30) on the front of the stationary saw.
2. To adjust height —
  - a. Loosen locking hand knob (Ref. No. 26). Rotate knob counterclockwise approximately three turns;
  - b. Turn hand wheel to desired blade height;
  - c. **CAUTION: For safety, blade should be raised only 1/8" above the surface of the material to be cut. However, if hollow ground blades are used, raise blade to its maximum height to allow for greater blade clearance;**
  - d. Lock blade height into position;
  - e. Lock hand wheel (Ref. No. 30) by tightening locking handknob (Ref. No. 26) clockwise. Tighten only until snug.

**IMPORTANT: DO NOT OVERTIGHTEN. ONLY A SMALL AMOUNT OF PRESSURE IS NECESSARY TO LOCK HAND WHEEL SECURELY.**

3. The blade height mechanism has upper and lower limit stops (Figure 3, Ref. Nos. 12 and 63). These limit stops are set at the factory and need no further adjustment.

C. BLADE TILT ADJUSTMENT (Figure 4)

1. The saw blade can be set at any angle between 90° and 45°.
2. Blade tilt is controlled by the hand wheel (Ref. No. 36) on the left side of the stationary saw. The indicator (Ref. No. 10) on front of saw shows at what angle the blade is tilted.
3. To adjust tilt —
  - a. Loosen locking hand knob (Ref. No. 26). Rotate knob counterclockwise at least three turns;
  - b. Turn hand wheel to desired blade angle;
  - c. Lock blade angle into position;
  - d. Lock hand wheel (Ref. No. 36) by tightening locking hand knob (Ref. No. 26) clockwise. Tighten only until snug.

4. The 12" stationary saw is equipped with positive stops at 90° and 45°. These positive stops allow the operator to position the saw blade at 90° and 45° quickly and accurately.

- a. Check 90° positive stop.
  - i. Raise the saw blade above table as far as possible;
  - ii. Set the blade at 90° to the table by turning the tilting hand wheel.
  - iii. Place a square on the table and check to see if blade is perpendicular (90°) to the table. When checking 90° put square flush against blade. Do not put square on "Set" of saw blade.
- b. If 90° adjustment is necessary:
  - i. Loosen locknut (Figure 3, Ref. No. 31) on adjusting screw (Figure 3, Ref. No. 33) and turn adjusting screw clockwise.
  - ii. Using the square, rotate the tilting hand wheel until certain blade is 90° to the table.
  - iii. When exactly at 90°, turn adjusting screw (Figure 3, Ref. No. 33) against the lug on the front trunnion (Figure 3, Ref. No. 27). Do not turn too far. Recheck 90°.
  - iv. Tighten locknut (Figure 3, Ref. No. 31) securely.
  - v. Check tilt indicator pointer. If necessary adjust pointer so it points to the "0" degrees mark on the scale. To adjust pointer, remove hand wheel (Fig. 4, Ref. No. 30) and loosen screw (Figure 3, Ref. No. 21). Be sure to tighten screw securely after adjustment is completed.
- c. Check 45° positive stop.
  - i. Tilt the saw blade to 45°.
  - ii. Using a combination square check to see if blade is 45° to the table.
- d. If 45° adjustment is necessary, adjust 45° stop in the same manner as the 90° stop. The only exception is that the adjustment bolt and locknut (Figure 3, Ref. Nos. 32 and 31) are on the other end of the rack. Adjust the indicator if necessary.

D. MITER GAUGE adjustment and operation (Figure 1)

1. The miter gauge supplied with the saw is equipped with individually adjustable index stops at 90° and 45°, right and left. Adjustment to the index stops can be made by loosening the locking nut (Ref. No. 13) and tightening or loosening the three adjusting screws (Ref. No. 5). Be sure to tighten locking nut (Ref. No. 13) after adjustment is made.
2. The face of the miter gauge has two holes for the purpose of attaching an auxiliary facing.
3. The miter gauge is accurately constructed for precision work. The miter gauge is guided through the "T" slot with a roller guide (Ref. No. 10) mounted at the front of the guide bar (Ref. No. 3). The roller guide adds to the miter gauge's stability and prevents the guide bar from leaving the "T" slot.
4. To operate the miter gauge, simply loosen the lock handle (Ref. No. 1) and move the miter gauge head (Ref. No. 4) to the desired angle. The miter gauge head will stop at 90° and 45°, both right and left. To position the miter gauge head past these points, simply push down the gauge stop (Ref. No. 7). Position miter gauge head at desired angle and tighten lock handle.

## Operation (Continued)

### E. RIP FENCE ASSEMBLY

THE STATIONARY SAW'S RIP FENCE ASSEMBLY IS PRECISION MANUFACTURED INCORPORATING "FIRE" ADJUSTMENT FOR ACCURATE

- 1pc FRONT RAIL
- 1pc REAR RAIL
- 1pc GUIDE RAIL
- 1SET FENCE ASSEMBLY WITH CLAMP HANDLE
- 1SET HARDWARE PACKAGE

#### ASSEMBLY PROCESS

1. BOLT THE FRONT RAIL TO THE TABLE FRONT SIDE WITH 4pc-M8×1.25p-16mm PAN HEAD SCREW, SET THE COMBINATION SQUARE AT 12mm, ADJUST THE FRONT RAIL TO BE 20mm BELOW THE TABLE SURFACE, LOCK IT (SEE FIG 1).
2. BOLT THE REAR RAIL TO THE TABLE BACK SIDE WITH 4pc M8-1.25p-30mm HEX SCREW, 4pc LOCK WASHER SET COMBINATION SQUARE AT 20mm, ADJUST THE REAR RAIL TO BE 12mm BELOW THE TABLE SURFACE.(SAME AS FIG 1).
3. BOLT THE GUIDE RAIL ON THE FRONT RAIL WITH 6pc-M8×1.25p-16mm 6pc LOCK WASHER.
4. PLACE THE FENCE ASSEMBLY ON THE TABLE AND LOCK IT ON GUIDE RAIL.

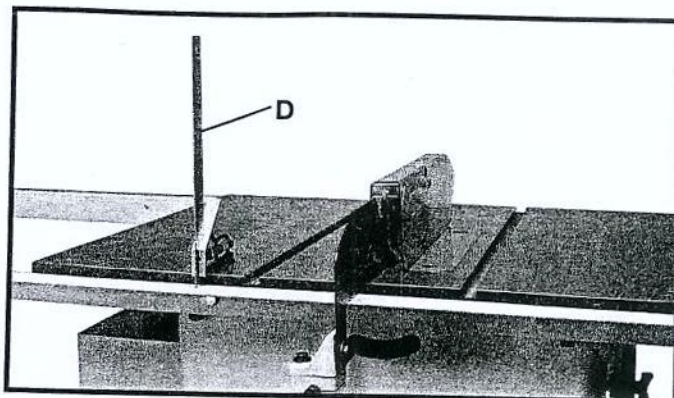

FIG 1

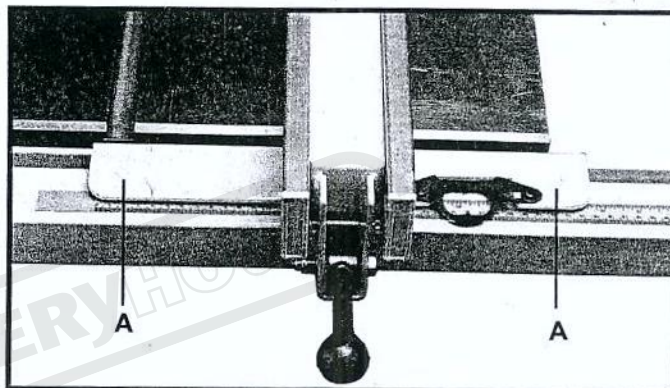

FIG 2

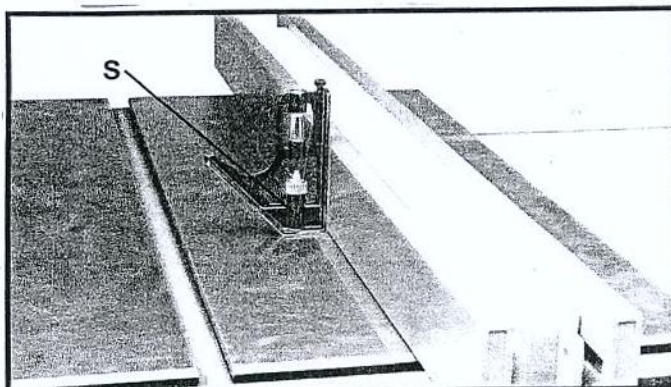

FIG 3

### F. RIP FENCE ADJUSTMENTS

1. LEVEL WITH THE TABLE  
THIS 12" SAW FENCE BRACKET THERE IS TWO NYLON SCREW (SEE FIG 2)A) CAN BE ADJUST RAISE OR LOWER TO CONTROL THE FENCE 90° TO THE TABLE, USED A SQUARE ON THE TABLE NEXT TO THE FENCE UNTIL THE FENCE IS 90° TO THE TABLE BY ADJUSTING SCREW. (SEE FIG 3).
2. PARALLEL TO THE MITRE SLOT  
PLACE THE FENCE NEXT TO THE EDGE LINE OF THE MITRE SLOT AND LOCK IT THE FENCE MUST BE EVEN WITH THE MITRE SLOT FROM FRONT TO REAR. IF NOT, ADJUST ONE OF TWO SETS SCREW LINE (SEE FIG 4)A) UNTIL THE FENCE IS EVEN WITH THE MITRE SLOT EDGE LINE ALONG ITS WHEN BE LOCKED.
3. CLAMPING PRESSURE  
THE 12" SAW RIP FENCE HAS BEEN ADJUSTED AT THE FACTORY TO LOCK SECURELY WHEN THE LOCK HANDLE IS PUSHED DOWN, IF ADJUSTED NECESSARY
  - a. UNLOCK FENCE LOCK HANDLE.
  - b. REMOVE THE FENCE FROM THE GUIDE RAIL.
  - c. ADJUST TWO SET SCREWS WITH 4mm ALLEN WRANGE UNTIL THE FENCE IS HELD SECURELY (SEE FIG 4)A) WHEN THE LOCK HANDLE IS PUSHED DOWN.

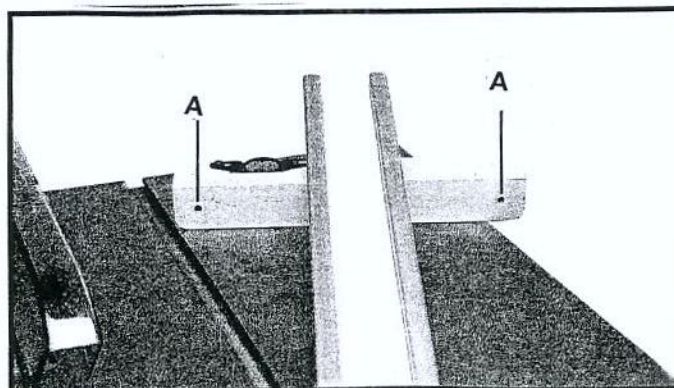

Fig. 4

## Operation (Continued)

4. MEASURE SCALE INDECADE ADJUSTMENTS  
A BOTH OF INCHES AND METRIC MEASURE SCALE HAS BEEN BUILT ON THE GUIDE RAIL AT THE FACTORY WHEN THE FENCE LEFT SIDE NEXT THE BLADE RIGHT SIDE LINE LENS INDICATE SHOULD BE POINT ON THE "0" POSITION IF NOT LOOSE 2 ROUND HEAD SCREW REMOVE LENS INDICATE BRACKET TO POINT ON "0" POSITION (SEE FIG 4).

**CAUTION**  
**DISCONNECT THE POWER SOURCE BEFORE ATTEMPTING ANY ASSEMBLY OR ADJUSTMENTS FENCE ASSEMBLY!**

**WARNING: FOR YOUR OWN SAFETY, ALWAYS OBSERVE THE FOLLOWING SAFETY PRECAUTIONS IN ADDITION TO THE SAFETY INSTRUCTION ON PAGES 2, 3 and 4.**

- a. Never make any cut freehand (without using miter gauge or rip fence because blade could bind in the cut and cause a kickback.
  - b. Always lock miter gauge or rip fence securely when in use.
  - c. Remove rip fence from the table when miter gauge is in use.
  - d. Remove miter gauge from table when rip fence is in use.
  - e. Make sure blade guard is installed for all "thru sawing" operations. Replace guard immediately after completion of resawing, rabbeting, and dadoing.  
Frequently check the action of the antikickback pawls by passing the workpiece alongside the spreader while saw is off. Pull the workpiece toward you. If the pawls do not dig into the workpiece and hold it, the pawls must be sharpened. (See Maintenance section.)
  - f. Have blade extend approximately 1/8" above top of workpiece. Additional blade exposure would increase the hazard potential.
  - g. Do not stand directly in front of the blade in case of a kickback. Stand to either side of the blade.
  - h. Keep your hands clear of the blade and out of the path of the blade.
  - i. If the blade stalls or stops while cutting, turn switch "OFF" and safety disconnect "OFF" before attempting to free the blade.
  - j. Do not reach over or behind the blade to pull the workpiece through the cut, to support long or heavy workpieces, to remove small cut-off pieces of material, or FOR ANY OTHER REASON.
  - k. Do not pick up small pieces of cut-off material from the table. Remove them by pushing them off the table with a long stick, otherwise, they could be thrown back at you by the rear of the blade.
9. Types of cuts/operations:
    - a. Crosscutting: Performed with miter gauge set at "0". Crosscutting is known as cutting wood across the grain at 90°, or square with both the edge and the flat side of the wood.
    - b. Miter cutting: Performed with miter gauge. is known as cutting wood at an angle other than 90° with the edge of the wood.
    - c. Bevel crosscutting: Performed with miter gauge is the same as crosscutting except that the wood is also cut at an angle other than 90° with the flat side of the wood (blade is at an angle).
    - d. Compound miter cutting: Performed with miter gauge, is a combination of miter cutting and bevel crosscutting. The cut is made at an angle other than 90° to both the edge and the flat side of the wood.
    - e. Ripping: Performed with rip fence, is known as cutting a piece of wood with the grain, or lengthwise. Position the fence to the desired width of rip and lock in place. When ripping long boards or large panels always use a work support.
    - f. Bevel ripping: Performed with rip fence, is the same as ripping. However, blade is set at an angle other than 90°.
    - g. Resawing: Performed with rip fence, is known as ripping a piece of wood through its thickness. Do not attempt to resaw bowed or warped material.  
NOTE: It may be necessary to remove blade guard and use work supports as well as push blocks when performing this operation. Install blade guard immediately upon completion of the resawing operation.
    - h. Ploughing: Performed with rip fence, is grooving with the grain the long way of the workpiece. Use proper holddowns and feed devices.
    - i. Rabbeting: Performed with either miter gauge or rip fence. Rabbeting is known as cutting out a section of the corner of a piece of material, across an end or along an edge. To make a rabbet requires cuts, which do not go all the way through the material. Therefore, the blade guard must be removed. **INSTALL BLADE GUARD IMMEDIATELY UPON COMPLETION OF RABBETING OPERATION.** Rabbet cuts can also be made using dado head.
    - j. Dadoing: Performed with either miter gauge or rip fence. Dadoing is done with a set of blades (dado set) rather than the standard 12" saw blades. The dado set is used to groove wood similar to ploughing and rabbeting. However, the dado set allows the operator to remove more material at one pass. The operator, with a dado set, can vary the width of cut up to 13/16". Instructions for operating the dado set are contained in owner's manual furnished with dado
- i. Do not remove small pieces of cut-off material that may become trapped inside the blade guard while the saw is running. This could endanger your hands or cause a kickback. Turn the saw off. After the blade has stopped turning lift the guard and remove the piece.
  - m. Always lower blade below table level when machine is not in use.

## Operation (Continued)

set. Dadoing requires cuts which do not go all the way through the material. Therefore, the blade guard must be removed.

Dado sets have different characteristics than saw blades. As a result, the table saw must be fitted with special parts that are furnished with the saw. The Dayton stationary saw dado set maximum capacity is 5/8" I.D. x 8" O.D. x 13/16" width. When using a dado set the following parts must be substituted (see Figure 3):

5/8" dado arbor extension (Ref. No. 83)

5/8" dado flange (not shown)

5/8" dado locknut (not shown)

Dado table insert (Figure 4, Ref. No. 52)

See Assembly, page 8, section D.

**IMPORTANT: ALWAYS USE CORRECT INSERT.**

When using the dado set: Use caution. Use feather boards and pushsticks as required.

**WARNING: ALWAYS REPLACE IMMEDIATELY THE 1/2" BLADE, BLADE GUARD AND SPREADER WHEN YOU ARE FINISHED DADOING.**

**NOTE:** To replace 12" blade, the standard 1" arbor extension (Ref. No. 83) must be used.

### 10. Cutting oversized workpieces.

When cutting long workpieces or large panels always support the workpiece that is not on the table. Use an adjustable roller stand or make a simple support by clamping a piece of plywood to a saw horse. Add facings to miter gauge or rip fence as needed.

**IMPORTANT: DO NOT ALLOW FACINGS TO INTERFERE WITH OPERATION OF BLADE GUARD.**

### 11. Dust collecting.

The saw is fitted with a 4" male exhaust port. When a dust collector is used, cover the louvers on the door. This will create a better vacuum within the cabinet resulting in more efficient saw dust removal. The door is louvered inward and has four 1/4" holes to accommodate a cover on the exterior of the door. A cover can be simply made with 1/8" plywood or plexiglass. It is also possible to tape louvers closed or seal with a sheet of plastic.

**IMPORTANT: IF DUST COLLECTOR IS NOT "ON" WHEN SAW IS RUNNING, BE SURE LOUVERS ARE OPEN. GOOD AIR CIRCULATION IS REQUIRED TO KEEP MOTOR FROM OVERHEATING.**

### 12. Before starting the machine, see that all adjustments are properly made and the guards are in place. With power disconnected, turn pulley by hand to make sure that everything is correct before connecting power and turning on machine.

### 13. Starting saw.

**WARNING: NEVER OPERATE SAW WITHOUT BLADE GUARDS IN PLACE. BE SURE THE BLADE IS NOT IN CONTACT WITH THE WORKPIECE WHEN THE MOTOR IS STARTED. START THE MOTOR AND ALLOW THE SAW TO COME UP TO FULL SPEED.**

**CAUTION: Make sure the electrical characteristics of the motor nameplate and the power source are the same.**

- a. The stationary saw is fitted with a safety ON/OFF switch on front left side of cabinet.
- b. To turn saw on, stand to either side of the blade — never in line with it. Push Green start. Always allow saw blade to come up to full speed before cutting.
- c. Do not cycle the motor switch "ON" and "OFF" rapidly. This action overheats the motor and may cause the saw blade to loosen.
- d. Never leave the saw while the power is on.
- e. To turn saw off, push red "Stop." Never leave saw until the cutting tool has come to a complete stop.
- f. **WARNING: FOR YOUR OWN SAFETY, LOWER BLADE OR OTHER CUTTING TOOL BELOW TABLE SURFACE. IF BLADE IS TILTED, RETURN IT TO VERTICAL (90°) POSITION. TURN OFF SAFETY DISCONNECT OR CIRCUIT BREAKER WHEN SAW IS NOT IN USE.**
- g. Blade selection  
Blade selection is based on the type of material being cut, as well as how it will be cut. There are three general types of saw blades.
  - i. *Rip* saws cut with the grain of the wood;
  - ii. *Cutoff* saws cut across the grain;
  - iii. *Combination* saws cut with the grain, across the grain, and also cut at any angle to the grain.

Blades vary in many aspects. When selecting a blade the following blade characteristics should be matched up with the operation to be performed as well as the type of material to be cut: type of steel, quality of steel; tooth style; tooth set; carbide tipped; grind; number of teeth and size.

The saw has a maximum blade capacity of 12". The arbor hole must be 5/8" or one inch. A high-quality all-purpose blade recommended for this table saw is a 12" carbide blade (1A065).

**IMPORTANT: YOUR 12" STATIONARY SAW IS ONLY AS ACCURATE AND EFFICIENT AS THE BLADE OR CUTTING TOOL BEING USED.**

First, be certain to use the appropriate type of cutting tool for the operation to be performed. Second, it is strongly recommended that high quality blades and cutting tools be used. Be certain blades and cutting tools are kept sharp and in good working order. Check blades periodically and replace or sharpen if necessary.

## Maintenance

**WARNING: MAKE CERTAIN THAT THE UNIT IS DISCONNECTED FROM THE POWER SOURCE BEFORE ATTEMPTING TO SERVICE OR REMOVE ANY COMPONENT!**

### A. CLEANING

Clean off any preservative on bright (machined) parts with appropriate solvent (kerosene or penetrating oil). Avoid getting cleaning fluid on any rubber parts as they tend to deteriorate the rubber. Use soap and soft water on rubber and plastic parts.

### Maintenance (Continued)

After cleaning, lubricate the unpainted surfaces with a light application of medium consistency machine oil. This lubrication should be repeated at least once every six months.

NOTE: Instead of oil, a good quality paste wax can be applied to the rip fence and table surface. Paste wax will enhance the movement of workpieces across the surface to which it is applied. In addition to being a lubricant, paste wax will help prevent surfaces from rusting.

Keep your machine and your workshop clean. Do not allow sawdust to accumulate on the stationary saw, or inside the saw cabinet. Frequently vacuum or blow out any sawdust that may accumulate within the cabinet. Be certain motor and internal mechanisms are kept clean and are frequently vacuumed or blown free of any dirt. For motor maintenance, follow instructions provided with the motor.

#### B. LUBRICATION

All bearings on the arbor are shielded ball bearings. These bearings are permanently lubricated at the factory.

As needed, clean the grease off the rack and worm gears of the height and tilt mechanism. Lubricate rack and gears with a medium viscosity grease.

Periodically lubricate all internal bearing or wear surfaces with a medium viscosity machine oil. Be sure to lubricate trunnion ways and all bushings.

Occasionally oil all other bearing points, including blade guard assembly, miter gauge, and rip fence.

For motor lubrication, follow instructions provided with motor.

#### C. SERVICE

Replace belts and worn parts when needed. If power cords are worn, cut or damaged in any way, have them replaced immediately.

Make sure the teeth of the antikickback pawls are always sharp. Sharpen the dull teeth using a few light strokes of a fine-cut round file.

Service motor according to the instructions provided. The motor should be worked on only by qualified technicians.

### Trouble Shooting Chart

SYMPTOM	POSSIBLE CAUSE(S)	CORRECTIVE ACTION
A. Excessive vibration	1. Blade out of balance. 2. Damaged V-belt pulleys or poor belt.	1. Discard blade and use a different blade. 2. Replace as indicated.
B. Cannot make square cut when crosscutting	Miter gauge not adjusted properly.	Adjust miter gauge (Operation page 10, Section D).
C. Blade stalls (however motor turns)	1. Belts not tight. 2. Belts not equal size 3. Belts worn	1. Adjust belt tension. 2. Replace belts. 3. Replace belts.
D. Cut binds, burns or stalls motor when ripping	1. Dull blade with improper tooth set 2. Blade is binding at one end of cut (heeling) 3. Warped board 4. Rip fence not parallel to blade 5. Spreader out of alignment.	1. Sharpen or replace blade. 2. Adjust table and rip fence parallel to blade 3. Make sure concave or hollow side is facing "down"; feed slowly. 4. Adjust rip fence (Operation, page 11, Section E). 5. Adjust spreader to fall in line with blade (Assembly, page 7, Section C [5]).
E. Cut not true at 90° or 45° positions	Positive stops not properly adjusted	Adjust blade tilt (Operation, page 10, Section C).
F. Tilt and elevating hand wheel is difficult to turn	1. Sawdust on rack and worm gears 2. Bushing collars too tight 3. Bushings and bearing surfaces need cleaning and lubrication	1. Clean and relubricate (Maintenance, page 13, Sections A & B). 2. Adjust properly 3. Clean thoroughly and lubricate
G. Excessive noise	Motor	Have motor checked by service technician. Consult owner's manual for motor.
H. Motor overheats	1. Motor overloaded 2. Improper cooling; restricted air circulation.	1. Feed work slower into blade. 2. Remove cover on louvers or clean out sawdust to provide normal air circulation through motor.
I. Frequent opening of fuses or circuit breakers.	1. Motor overloaded 2. Fuses or circuit breakers do not have sufficient capacity.	1. Feed work slower into blade. 2. Install proper size fuses or circuit breakers.
J. Motor stalls (resulting in blown fuses or tripped circuit breakers).	Starting switch not operating	Have switch replaced.
K. Motor problems in general		To trouble shoot and service motor, consult owner's manual provided with motor.

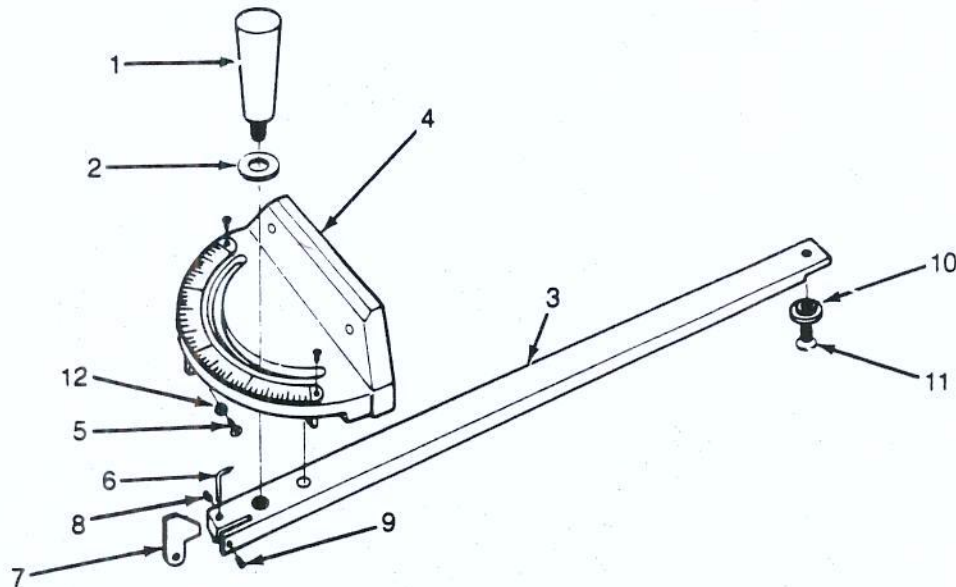

Figure 1 — Replacement Parts Illustration for Miter Gauge

### Replacement Parts List for Miter Gauge

REF. NO.	DESCRIPTION	PART NO.	QTY.	REF. NO.	DESCRIPTION	PART NO.	QTY.
1	Handle	1086.00	1	7	Miter gauge stop	1092.00	1
2	Washer, 10mm	1087.00	1	8	Setscrew, 6mm - 1.0 x 6	0964.00	1
3	Bar	1088.00	1	9	Setscrew, 6mm - 1.0 x 6	0964.00	1
4	Gauge	1089.00	1	10	Roller guide	1093.00	1
5	Round hd. screw, 5mm - .80 x 20	1090.00	3	11	Flat head screw, 6mm - 1.0 x 8	1095.00	1
6	Indicator	1091.00	1	12	Locking nut, 5mm - .80	0985.00	3

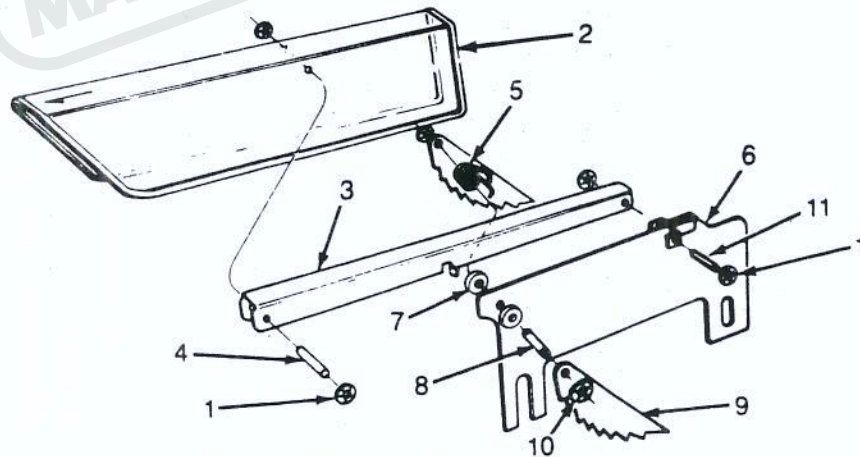
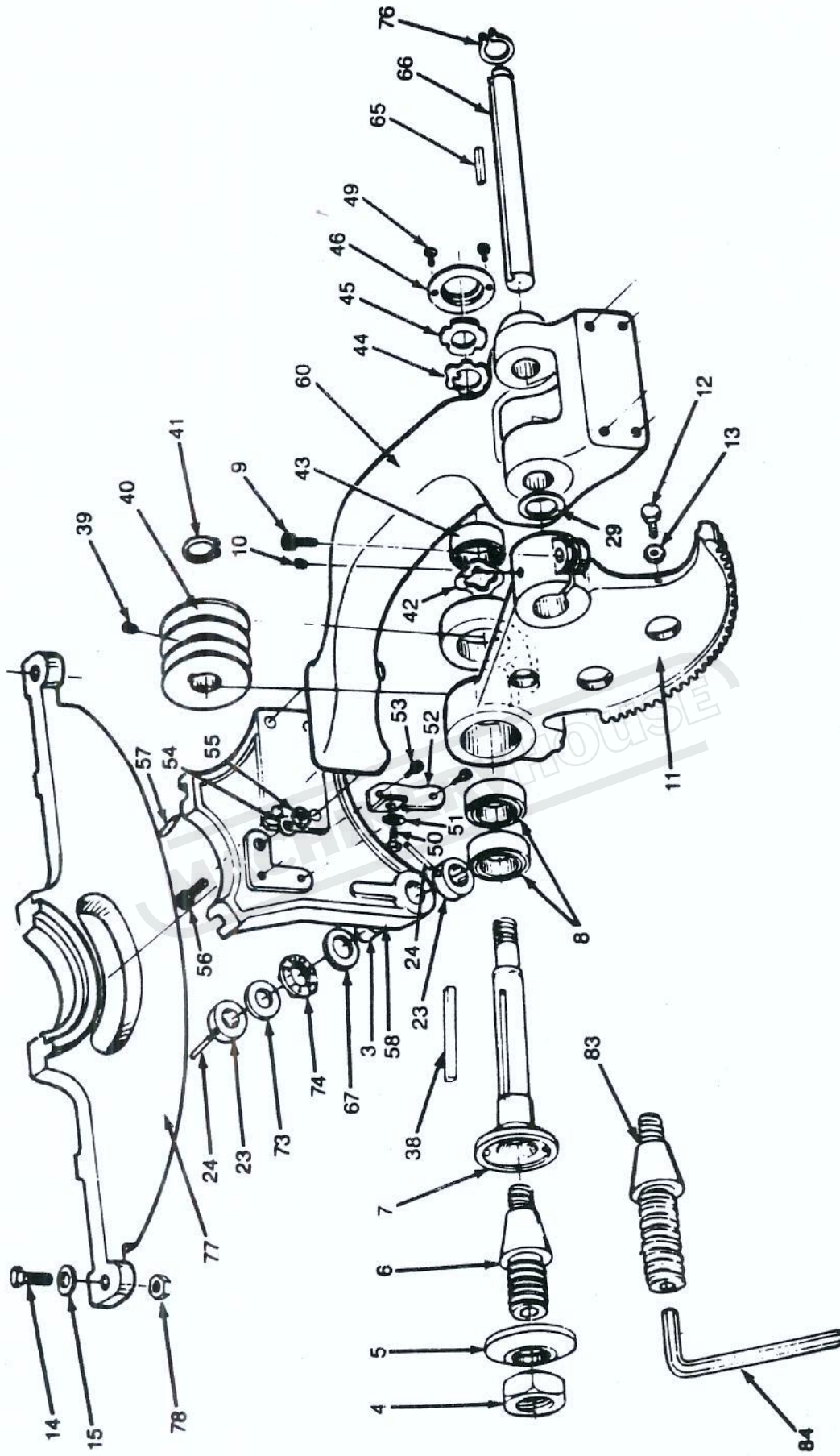

Figure 2 — Replacement Parts Illustration for Guard Assembly

### Replacement Parts List for Guard Assembly

REF. NO.	DESCRIPTION	PART NO.	QTY.	REF. NO.	DESCRIPTION	PART NO.	QTY.
1	Push nut	1069.00	4	6	Spreader	1074.00	1
2	Clear blade guard	1070.00	1	7	Spacer	1075.00	2
3	Guard support	1071.00	1	8	Pin	1076.00	1
4	Pin	1072.00	1	9	Antikickback pawl	1077.00	2
5	Spring	1073.00	1	10	Snap ring	1078.00	2
				11	Pin	1079.00	1





**Replacement Parts List for Main Mechanism**

REF. NO.	DESCRIPTION	PART NO.	QTY.
1	Washer	0950.00	2
2	Bushing	0951.00	2
3	Bushing	0951.00	2
4	Arbor nut (1" I.D.)	0952.00	1
5	Blade flange (1" I.D.)	0953.00	1
6	Arbor extension (for 1" O.D. blade)	0954.00	1
7	Arbor	0955.00	1
8	Bearing	0956.00	2
9	Socket head bolt, 8mm - 1.25 x 25	0957.00	1
10	Setscrew, 8mm - 1.25 x 8	0958.00	1
11	Arbor bracket	0959.00	1
12	Hex head bolt, 6mm - 1.0 x 12	0960.00	1
13	Hex nut, 6mm - 1.0	0961.00	1
14	Hex head bolt, 10mm - 1.5 x 35	0962.00	4
15	Lockwasher, 10mm	0963.00	4
16	Setscrew, 6mm - 1.0 x 6	0964.00	2
17	Indicator bracket	0965.00	1
18	Socket head bolt, 5mm - .80 x 75	0966.00	2
19	Indicator	0967.00	1
20	Washer, 5mm	0968.00	1
21	Round head screw, 5mm - .80 x 8	0969.00	1
22	Collar	0970.00	1
23	Collar	0970.00	2
24	Roll pin	0971.00	5
25	Limit stud	0972.00	4
26	Tilt adjustment shaft	0973.00	1
27	Front trunnion bracket	0974.00	1
28	Key, 5mm x 5mm x .25	0975.00	2
29	Washer	0976.00	1
30	Front trunnion	0977.00	1
31	Hex nut, 8mm - 1.25	0978.00	2
32	Hex head bolt, 8mm - 1.25 x 35	0979.00	1
33	Hex head bolt, 8mm - 1.25 x 35	0979.00	1
34	Pivot shaft	0980.00	1
35	Hex head bolt, 12mm - 1.75 x 15	0981.00	2
36	Washer, 12mm	0982.00	2
37	Cotter pin	0983.00	1
38	Key, 5mm x 5mm x .45	0984.00	1
39	Setscrew, 8mm - 1.25 x 8	0958.00	1
40	Drive pulley	0986.00	1
41	Snap ring, R22	0987.00	1
42	Bearing washer	0988.00	1
43	Bearing	0989.00	1
44	Washer	0990.00	1
45	Locking nut, 20mm	0991.00	1
46	Cover	0992.00	1

**Replacement Parts List for Main Mechanism (Continued)**

REF. NO.	DESCRIPTION	PART NO.	QTY.
47	Socket head bolt, 6mm - 1.0 x 12	0993.00	2
48	Dust deflector	0994.00	1
49	Round head screw, 5mm - .80 x 8	0969.00	3
50	Hex head bolt, 8mm - 1.25 x 12	0996.00	1
51	Washer, 8mm	0997.00	1
52	Front support bracket	0998.00	1
53	Socket head bolt, 6mm - 1.0 x 12	0963.00	2
54	Lockwasher, 12mm	1000.00	1
55	Hex nut, 12mm - 1.75	1001.00	1
56	Socket head bolt, 10mm - 1.5 x 25	1002.00	4
57	pin,	1003.00	2
58	Rear trunnion bracket	1004.00	1
59	pin,	1005.00	2
60	Arm	1006.00	1
61	Setscrew, 6mm - 1.0 x 6	0964.00	2
62	Motor mount support	1008.00	1
63	Hex head bolt, 8mm - 1.25 x 35	0979.00	1
64	Hex nut, 8mm - 1.25	0978.00	1
65	Key, 5mm x 5mm x 75mm	1011.00	1
66	Shaft	1012.00	1
67	Washer	1013.00	2
68	Worm gear	1014.00	2
69	Lockwasher, 10mm	0963.00	4
70	Hex nut, 10mm	1016.00	4
71	Motor mount plate	1017.00	1
72	Hex head bolt, 10mm - 1.5	1018.00	4
73	Bearing dust deflector	1019.00	1
74	Thrust bearing, #51104	1020.00	1
75	Height adjustment shaft	1021.00	1
76	Snap ring, R28	1022.00	1
77	Rear trunnion bracket	1023.00	1
78	Hex nut, 10mm	1016.00	4
80	Motor pulley,	1026.00	1
81	Setscrew, 8mm - 1.25 x 8	0958.00	1
82	V-belt,	4LZ90	3
83	Arbor extension (for Dado) (OPTIONAL)	1028.00	1
84	Setscrew wrench, 8mm	0889.00	1
85	Spanner wrench	1032.00	1
86	Blade (OPTIONAL)	1036.00	1
△	Setscrew wrench, 5mm	0150.00	1
△	Setscrew wrench, 3mm	0149.00	1
△	Spanner 12 x 14 wrench	1034.00	1
△	Spanner 17 x 19 wrench	1035.00	1

△Not shown.

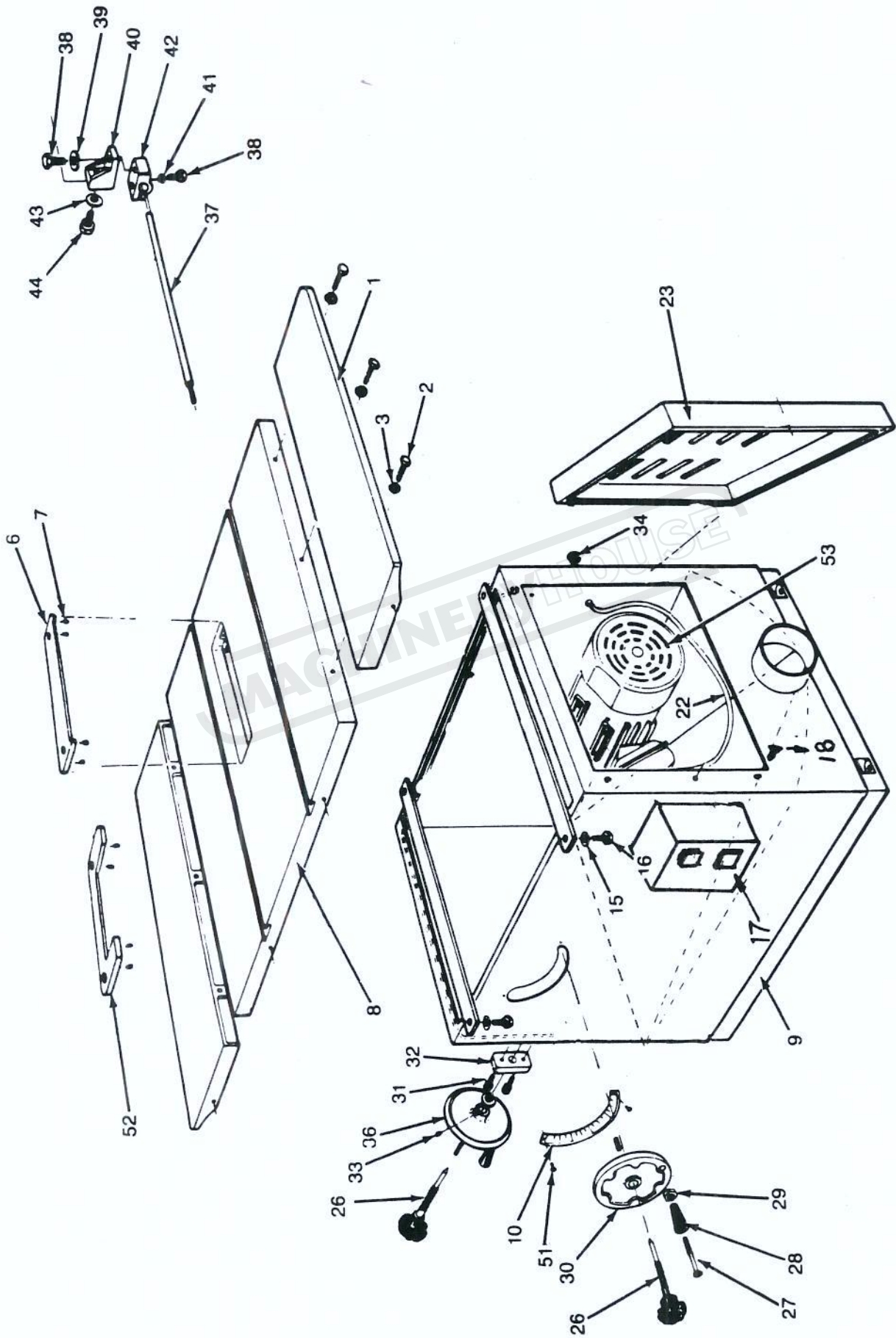

Figure 4 — Replacement Parts Illustration for Table and Base Assembly

### Replacement Parts List for Table and Base Assembly

REF. NO.	DESCRIPTION	PART NO.	QTY.
1 2 3	Extension table Hex head bolt, 10mm- 1.5 x 35 Lockwasher, 10mm	1037.00 0962.00 0963.00	2 6 6
6 7 8	Blade insert Setscrew, 6mm - 1.0 x 8 Table	1042.00 1043.00 1044.00	1 4 1
9 10 11	Base Indicator plate Round head screw, 4mm - .60 x 25	1045.00 1046.00 1047.00	1 1 2
13	Nut, 4mm - .60	1049.00	2
15 16	Lockwasher, 10mm Hex head bolt, 10mm - 1.5 x 30	0963.00 1051.00	4 4
17 18 19	Magnetic switch Round head screw, 5mm - .80 x 8 Locknut, 5mm - .80	1052.00 0969.00 1053.00	1 2 2
22 23	Line cord (Mag. to motor) Door	1055.00 1056.00	1 1
26 27 28	Locking knob Screw Crank handle	1059.00 1060.00 1061.00	2 2 2
29 30 31 32	Hex nut Hand wheel (tilting) Socket head bolt, 8mm - 1.25 x 20 Shield plate	1062.00 1063.00 1064.00 1065.00	2 1 2 1
33 34 35 36	Setscrew, 6mm - 1.0 x 6 Grommet Lockwasher, 4mm Hand wheel (height)	0964.00 1066.00 1067.00 1063.00	2 1 2 1
37 38 39 40	Guard support rod Hex head bolt, 8mm - 1.25 x 25 Washer, 8mm Rear spreader support (upper)	1080.00 1081.00 0997.00 1083.00	1 2 1 1
41 42 43 44	Lockwasher, 8mm Rear spreader support (lower) Washer, 8mm Hex head bolt, 8mm - 1.25 x 12	1084.00 1085.00 0997.00 0996.00	1 1 1 1
51 52 53	Screw Dado insert (OPTIONAL) Motor	1010.00 0999.00 6K146	2 1 1

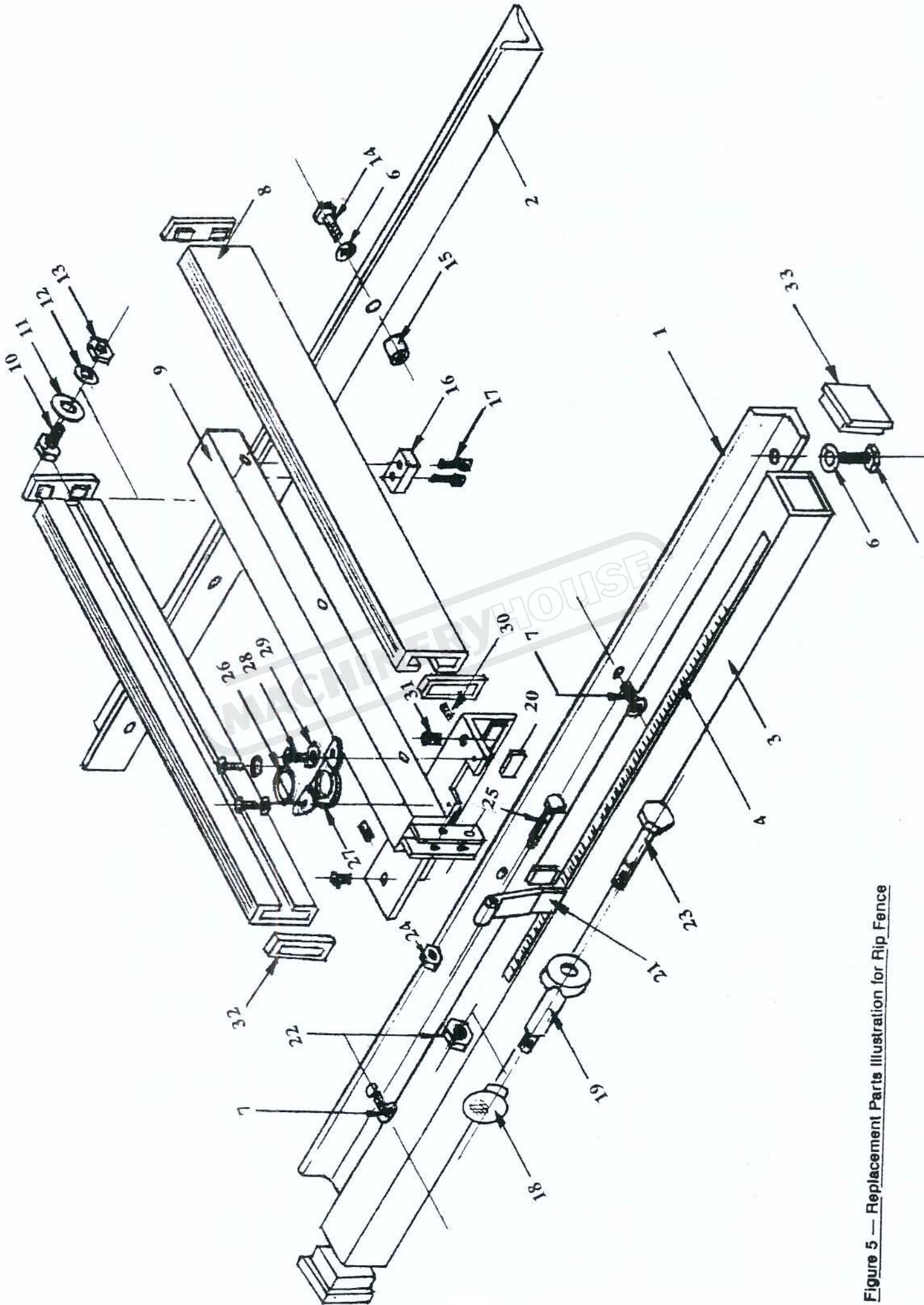

Figure 5 — Replacement Parts Illustration for Rip Fence

### Replacement Parts List for Rip Fence

REF. NO.	DESCRIPTION	PART NO	QTY
1	FRONT RAIL	2001.00	1
2	REAR RAIL	2002.00	1
3	GUIDE RAIL	2003.00	1
4	MEASURE SCALE	2004.00	1
5	HEX HEAD SCREW M8 × 16mm	2219.00	6
6	LOCK WASHER	0978.00	10
7	PAN HEAD SCREW M8 × 16mm	2005.00	3
8	FENCE	2006.00-A	2
9	FENCE BRACKET BODY	2007.00	1
10	HEX HEAD SCREW M10 × 20mm	2220.00	6
11	WASHER	2223.00	6
12	LOCK WASHER	0963.00	6
13	HEX NUT	1016.00	6
14	HEX HEAD SCREW M8 × 30mm	2221.00	3
15	SPACER	2009.00	4
16	PLASTIC PAD	2010.00	1
17	SOCKET HEAD SCREW M5 × 15mm	2222.00	2
18	LOCK KNOB	2011.00	1
19	CAM WITH LOCKING LEVER	2012.00	1
20	PAD	2013.00	3
21	CLAMP SHOE	2014.00	1
22	LOCK NUT	2211.00	1
23	HEX HEAD BOLT 3/8" × 1 3/4"	2212.00	1
24	LOCK NUT	2213.00	1
25	HEX HEAD BOLT M6 × 45mm	2214.00	1
26	LENS	2015.00	1
27	LENS BRACKET	2016.00	1
28	ROUND HEX SCREW M5 × 8mm	1212.00	3
29	WASHER	2215.00	3
30	SET SCREW M8 × 12mm	2216.00	2
31	PLASTIC SCREW	2017.00	2
32	FENCE END COVER	2018.00	4
33	RAIL END COVER	2019.00	2
△	ALEN WRENCH 4m/m	2217.00	1
△	ALEN WRENCH 5m/m	2218.00	1

---

**OPERATIONS MANUAL FOR  
4' X 8' ROLLER TYPE SLIDING TABLE**

---

- Open crate with Sliding Table Assembly and fit Part #9 (has bearing in) to lower holes on left hand side of saw (see parts drawing supplied with sliding table).
- Remove #40 Swinging Arm with #42 Pivot Pin Installed, and place on #9 Lower Bearing Block.
- Bolt on #8 Upper Block with pivot pin inserted in between 3 x Adjustment Screws (screws to top of block).
- Remove #11 long Steel sliding Bar and bolt 2 x #12 Blocks to it (as shown).
- Bolt this bar to the left hand side of the saw bench as shown. Nip up attachment bolts with bar in upper position of slots (for Future adjustment).
- With #1 Main Siding Assembly still in box, attachment #31 "Y" Arm to end of assembly with #34 Plastic Knob facing out.
- Fit #37 Outrigger Roller into "Y" arm and tighten knob. Then place siding table onto saw rails.
- Fit #17 Collar to far end of #11 Steel Bar.
- Fit #16 Collar (with bar welded on) to front end of #11 Steel Bar with #33 Adjustable Outrigger Leg fitted.
- Fit 2 x #15 Lower Bearing Supports to right hand side of bottom of #1 Sliding Table Assembly. When fitting, bearing shaft is on a cam. by undoing #23 Grub Screw on underside of casting. The bearing shaft can be rotated which will move the bearing up and down.
- At this stage it is recommended that the table adjustment be done. To do this, a lot of trial and error is involved to achieve the desired result.

Position sliding table between the two #12 Brackets then adjust down #11 Bar so #1 sliding Table is in line with saw bench (just above and parallel). Now fine set up the #11 sliding Bar so both sides at front and back of saw are even (use a straight edge of the table and a ruler from straight edge to bar to measure distance (approx, 70mm)).

- Remove #17 collar and slide table assembly off. Swing #40 Swinging Arm to front of machine, under #11 Rod, and adjust screws in #8 Upper Block so that 2 x #11 and #41 Rails are parallel. At the same time, adjust the #41 Arm Rail at 90° to the #11 Rail, using #24 Fence on table top, as a straight edge. This should be parallel as well. When all is set, replace sliding table back onto rails and refit #17 Collar.

- Now, by sitting #24 Fence on #1 Sliding Table, the sliding table can be adjusted parallel and just above saw bench top.

To do this, the bearing shafts on the 2 upper vee wheels can be turned to move the table up and down. Loosen grub screws first. (Note: the lower bearings will have to be adjusted to suit as this is done). Also the #37 Outrigger Roller can be adjusted up and down by turning #32 Knob as needed. Swing arm pivot shaft may also have to be adjusted (3x Screws in #8 Block). Keep on adjusting all the above until the desired result is achieved.

- Fit #20 Extension Frame onto #1 Table.
- Fit 2 x #18 Fence Bracket to sliding table and fit #24 Fence to them.
- Fit #6 Swivel Work Stop onto #24 Fence.
- Fit #(not shown) Long Work Stop onto end of #25 Work Stop Tube.

**MACHINERYHOUSE**

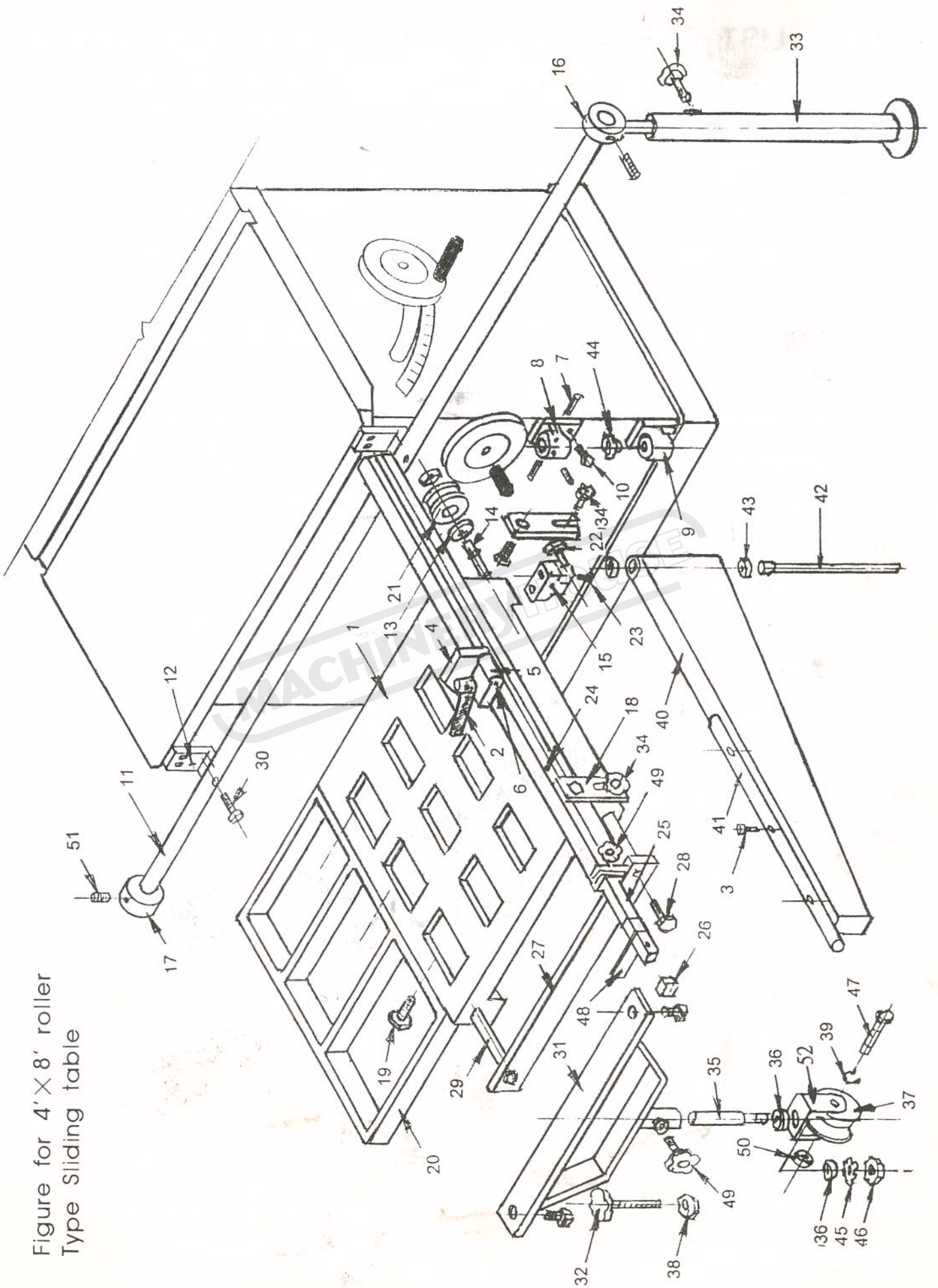
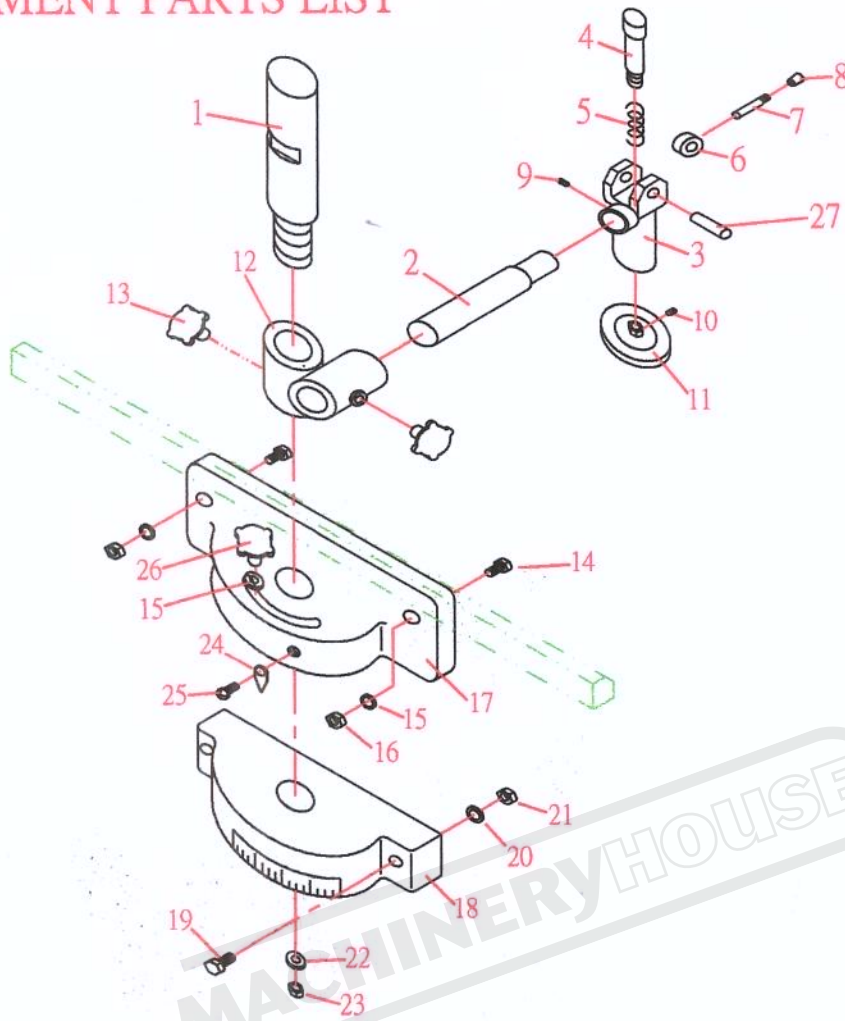

Figure for 4' X 8' roller  
Type Sliding table

## PARTS LIST FOR 4'X8' ROLLER TYPE SLIDING TABLE

PARTS NO	DESCREPTION	Q'TY	PARTS NO	DESCREPTION	Q'TY
1.	MAIN TABLE	1	26.	END. COVER	1
2.	LOCK HANDLE	1	27.	CONNECTING PLATE	1
3.	SOCKET SCREW	3	28.	M8. HEX HD SCREW	2
4.	STOPS	1	29.	EXTENSION BAR	2
5.	STOPS OF BKT	1	30.	SOCKET SCREW	2
6.	ROUND PIN	1	31.	SUPPORT BKT	1
7.	SET SCREW M8	3	32.	AD JUSTING KNOB	1
8.	UPPER BKT	1	33.	SUPPORT ROD	1
9.	LOWER BKT	1	34.	LOCK KNOB	1
10.	M10. HEX HD SCREW	4	35.	SHAFT	1
11.	ROUND BAR	1	36.	THRUST BEARING	2
12.	HANGER	2	37.	SLIDING ROLLER	1
13.	BEARING	4	38.	NUT	1
14.	ROLLER SHAFT	2	39.	E-TYPE RING	3
15.	LOWER ROLLER SUPPORT	2	40.	SWING BODY	1
16.	FRONT STOP RING	1	41.	ROUND BAR	1
17.	REAR STOP RING	1	42.	SHAFT	1
18.	STEEL PLATE	2	43.	BEARING	2
19.	M10. HEX HD SCREW	3	44.	SPHERICAL BEARING	1
20.	EXTENSION TABLE	1	45.	WASHER	1
21.	UPPER ROLLER	2	46.	LOCK NUT	1
22.	BEARING	2	47.	ROLLER PIN	1
22-1.	BEARING SHAFT	2	48.	STOPS	1
23.	M8. HEX HD SCREW	4	49.	LOCK KNOB	2
24.	CROSS FENCE	1	50.	BEARING #6001ZZ	2
24-1.	MEASURE TAPE	1	51.	SET SCREW M8	2
25.	EXTENSION TUBER	1	52.	ROLLER SUPPORT	1

# HOLD DOWN CLAMP WITH MITRE SYSTEM FOR SLIDING TABLE REPLACEMENT PARTS LIST



R/NO	P/NO	DESCRIPTIONS	Q,TY	R/NO	P/NO	DESCRIPTIONS	Q,TY
1	HD-01	VERTICAL ROD	1	15	HD-15	M10 FLAT WASHER	2
2	HD-02	SHAFT	1	16	HD-16	M10 HEX NUT	2
3	HD-03	HOLD DOWN BRACKET	1	17	HD-17	UPPER MITRE GUAGE	1
4	HD-04	CLAMP SHAFT	1	18	HD-18	LOWER MITRE BODY (W/SCALE)	1
5	HD-05	SPRING	1	19	HD-19	M8x35L HEX HEAD SCREW	2
6	HD-06	LOCKING CAM	1	20	HD-20	M8 FLAT WASHER	2
7	HD-07	LOCK HANDLE	1	21	HD-21	M8 HEX NUT	2
8	HD-08	KNOB	1	22	HD-22	5/8" FLAT WASHER	1
9	HD-09	M8x8 SET SCREW	1	23	HD-23	5/8" HEX NUT	1
10	HD-10	M6x6 SET SCREW	1	24	HD-24	POINTER	1
11	HD-11	PLATE	1	25	HD-25	M5x8 ROUND HEAD SCREW	1
12	HD-12	PIVOT BRACKET	1	26	HD-26	LOCK KNOB	1
13	HD-13	LOCK KNOB	2	27	HD-27	DOWL PIN	1
14	HD-14	M10x30L HEX HEAD SCREW	2				

# RIVING KNIFE & OVERHEAD SUVA GUARD FOR W459

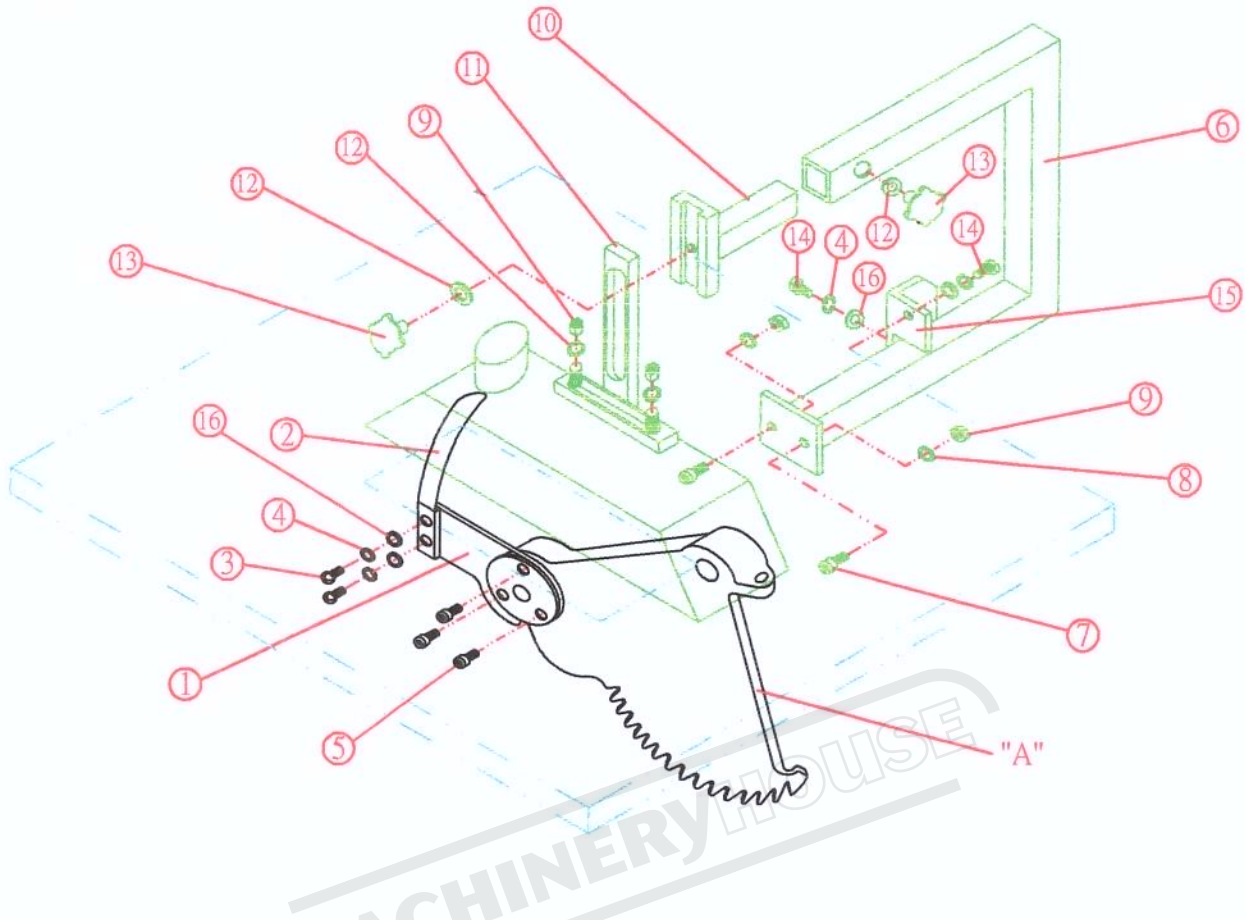

## ASSEMBLY OF RIVING KNIFE AND OVERHEAD SUVA GUARD

1. LOCKED RIVING KNIFE SUPPORT ON ARBOR BRACKET "A" WITH 3PCS M5x16L SOCKET HEAD SCREW
2. LOCKED RIVING KNIFE ON SUPPORT WITH 2PCS M8x16L ROUND HEAD SCREW WITH M8 LOCK WASHER AND ADJUSTING TOLORANCE WITHIN 6mm BETWEEN SAW BLADE AND RIVING KNIFE.
3. MOUNTED GUARD ARM ON CABINET BY 2PCS M10x25L SOCKET HEAD SCREW WHERE ARE ON THE RIGHT SIDE OF CABINET.
4. MOUNTED SAW GUARD ON EXTENSIONS BAR AND ADJUSTING HIGHT OVER 4 INCHS ABOVE TABLE AND ADJUSTING THE GUARD ON CENTRE LINE OF BLADE.
5. LOCK THE KNOB (13)

## PART LIST

P/NO	DESCRIPTIONS	Q,TY	P/NO	DESCRIPTIONS	Q,TY
1	RIVING KNIFE SUPPORT	1	9	M10 HEX NUT	4
2	RIVING KNIFE	1	10	EXTENSION BAR	1
3	M8x16L ROUND HEAD SCREW	2	11	"T" BRACKET WITH GUARD	1
4	M8 LOCK WASHER	4	12	M10 FLAT WASHER	4
5	M5x16L SOCKET HEAD SCREW	3	13	LOCK KNOB	2
6	ARM FOR GUARD	1	14	M8x20L HEX HEAD SCREW	2
7	M10x25L SOCKET HEAD SCREW	2	15	GUARD ARM HOLDER	1
8	M10 LOCK WASHER	2	16	M8 FLAT WASHER	4



# WARNING

## General Machinery Safety Instructions

---

Machinery House  
requires you to read this entire Manual before using this machine.

- 1. Read the entire Manual before starting machinery.** Machinery may cause serious injury if not correctly used.
- 2. Always use correct hearing protection when operating machinery.** Machinery noise may cause permanent hearing damage.
- 3. Machinery must never be used when tired, or under the influence of drugs or alcohol.** When running machinery you must be alert at all times.
- 4. Wear correct Clothing.** At all times remove all loose clothing, necklaces, rings, jewelry, etc. Long hair must be contained in a hair net. Non-slip protective footwear must be worn.
- 5. Always wear correct respirators around fumes or dust when operating machinery.** Machinery fumes & dust can cause serious respiratory illness. Dust extractors must be used where applicable.
- 6. Always wear correct safety glasses.** When machining you must use the correct eye protection to prevent injuring your eyes.
- 7. Keep work clean and make sure you have good lighting.** Cluttered and dark shadows may cause accidents.
- 8. Personnel must be properly trained or well supervised when operating machinery.** Make sure you have clear and safe understanding of the machine you are operating.
- 9. Keep children and visitors away.** Make sure children and visitors are at a safe distance for you work area.
- 10. Keep your workshop childproof.** Use padlocks, Turn off master power switches and remove start switch keys.
- 11. Never leave machine unattended.** Turn power off and wait till machine has come to a complete stop before leaving the machine unattended.
- 12. Make a safe working environment.** Do not use machine in a damp, wet area, or where flammable or noxious fumes may exist.
- 13. Disconnect main power before service machine.** Make sure power switch is in the off position before re-connecting.
- 14. Use correct amperage extension cords.** Undersized extension cords overheat and lose power. Replace extension cords if they become damaged.
- 15. Keep machine well maintained.** Keep blades sharp and clean for best and safest performance. Follow instructions when lubricating and changing accessories.
- 16. Keep machine well guarded.** Make sure guards on machine are in place and are all working correctly.
- 17. Do not overreach.** Keep proper footing and balance at all times.
- 18. Secure workpiece.** Use clamps or a vice to hold the workpiece where practical. Keeping the workpiece secure will free up your hand to operate the machine and will protect hand from injury.
- 19. Check machine over before operating.** Check machine for damaged parts, loose bolts, Keys and wrenches left on machine and any other conditions that may effect the machines operation. Repair and replace damaged parts.
- 20. Use recommended accessories.** Refer to instruction manual or ask correct service officer when using accessories. The use of improper accessories may cause the risk of injury.
- 21. Do not force machinery.** Work at the speed and capacity at which the machine or accessory was designed.
- 22. Use correct lifting practice.** Always use the correct lifting methods when using machinery. Incorrect lifting methods can cause serious injury.
- 23. Lock mobile bases.** Make sure any mobile bases are locked before using machine.
- 24. Allergic reactions.** Certain metal shavings and cutting fluids may cause an allergic reaction in people and animals, especially when cutting as the fumes can be inhaled. Make sure you know what type of metal and cutting fluid you will be exposed to and how to avoid contamination.
- 25. Call for help.** If at any time you experience difficulties, stop the machine and call you nearest branch service department for help.



# WARNING

## Sawbench/Panel Saw Safety Instructions

---

Machinery House  
requires you to read this entire Manual before using this machine.

- 1. Maintenance.** Make sure the saw is turned off and disconnect from the main power supply and make sure all moving parts have come to a complete stop before any inspection, adjustment or maintenance is carried out.
- 2. Saw Condition.** Saw must be maintained for a proper working condition. Never operate a saw that has damaged or worn parts. Scheduled routine maintenance should be performed on a scheduled basis.
- 3. Blade Condition.** Never operate a saw with a dropped, cracked or badly worn blade. Before using a saw inspect blades for missing teeth and cracks. A damaged blade can cause serious injury.
- 4. Replacing Blade.** Make sure teeth are face forward to the workpiece. Wear gloves to protect hands.
- 5. Hand Hazard.** Keep hands and fingers clear from the line of cut of the blade. Serious injury can occur.
- 6. Leaving a saw Unattended.** Always turn the saw off and make sure all moving parts have come to a complete stop before leaving the saw. Do not leave saw running unattended for any reason.
- 7. Avoiding Entanglement.** Blade guard must be used at all times. Remove loose clothing, belts, or jewelry items. Never wear gloves while machine is in operation. Tie up long hair and use the correct hair nets to avoid any entanglement with the saw moving parts.
- 8. Understand the machines controls.** Make sure you understand the use and operation of all controls.
- 9. Power outage.** In the event of a power failure during use of the saw, turn off all switches to avoid possible sudden start up once power is restored.
- 10. Work area hazards.** Keep the area around the saw clean from oil, tools, chips. Pay attention to other persons in the area and know what is going on around the area to ensure unintended accidents.
- 11. Workpiece Handling.** Workpiece should be stable on the table and support either by the rip fence or crosscut table during cutting. Hold downs, push sticks and featherboards and other safety devices can be used to make cutting operations safe.
- 12. Hearing protection and hazards.** Always wear hearing protection as noise generated from saw blade and workpiece vibration can cause permanent hearing loss over time.
- 13. Saw Blade Hazards.** Never reach behind or over a blade with your hands while saw is operating. If you lose your balance or kick back occurs you could be pulled into the spinning saw blade.
- 14. Operator position.** Never stand or have any part of your body in line with cutting path of the saw blade.
- 15. Use a Push Stick.** Always use a push stick when ripping narrow material.
- 16. Blade guards & blade splitter.** Always use blade guards and blade splitter when cutting completely through the workpiece.
- 17. Crosscutting operation.** While using a mitre guide to crosscut a workpiece, remove the rip fence.
- 18. Stalled blade.** In the case that the blade stalls while in operation, turn the saw off before freeing the stalled saw blade.
- 19. Blade height.** Always adjust blade to the correct height above the workpiece.
- 20. Kickback.** Kickback is defined as high speed expulsion of workpiece from the table saw towards the operator.
- 21. Call for help.** If at any time you experience difficulties, stop the machine and call your nearest branch service department for help.

# PLANT SAFETY PROGRAM

## NEW MACHINERY HAZARD IDENTIFICATION, ASSESSMENT & CONTROL

### Sawbench - Panel Saw

Developed in Co-operation Between A. W. I. S. A and Australia Chamber of Manufactures  
 This program is based upon the Australian Worksafe Standard for Plant(NOHSC:1010-1994)

Item No.	Hazard Identification	Hazard Assessment	Risk Control Strategies <small>(Recommended for Purchase / Buyer / User)</small>
A	ENTANGLEMENT	HIGH	Eliminate, avoid loose clothing / Long hair etc.
B	CRUSHING	LOW	Ensure machine is bolted down to prevent it falling.
C	CUTTING, STABBING, PUNCTURING	MEDIUM	Isolate main power switch before changing blade, cleaning or adjusting. Check blade is tight and in good condition before starting. Make sure blade guard is down and adjusted when changing thickness. Ensure blade is at the correct height when cutting. Hands must always be kept well away from blade at all times. Use a push stick where required.
D	SHEARING	MEDIUM	Make sure all guards are secured shut when machine is on.
F	STRIKING	LOW	Support long heavy workpieces and stand clear of offcuts falling. Remove all loose objects around moving parts. Wear safety glasses.
H	ELECTRICAL	MEDIUM	All electrical enclosures should only be opened with a tool that is not to be kept with the machine.
K	ERGONOMIC	MEDIUM	Machine should be installed & checked by a Licensed Electrician.
O	OTHER HAZARDS, NOISE, DUST.	LOW	Heavier pieces must be carried by more than one person, or use supports. Wear hearing protection as required. Must be connected to dust extraction.

Plant Safety Program to be read in conjunction with manufactures instructions



[www.machineryhouse.com.au](http://www.machineryhouse.com.au)



[www.machineryhouse.co.nz](http://www.machineryhouse.co.nz)

Authorised and signed by:  
 Safety officer: .....

Manager: .....

Revised Date: Aug-08